

# CD HORIZON<sup>®</sup> Spinal System

## M8 Multi Axial Screw Surgical Technique



as described by:

**Thomas G. Lowe, MD**

Clinical Professor  
of Orthopaedics

University of Colorado  
Health Sciences Center

University Hospital  
Department of  
Orthopaedic Surgery



Preface .....	2
Implants .....	3
Instruments .....	4
Surgical Technique Steps	
Multi Axial Screw Insertion .....	6
Construct Assembly.....	7
Rod Insertion.....	8
Compression/Distractio n .....	10
Final Tightening .....	11
Bone Grafting, CROSSLINK® Technique and Closure .....	12
Postoperative Care and Mobilization.....	13
Product Ordering Information	
M8.....	14
Low Profile CROSSLINK® Plates .....	15
Important Product Information.....	16

Since first used by Dr. Paul Harrington in the late 1960's, pedicle screws have gone through multiple phases and changes. For several indications, pedicle screws are currently viewed as a needed addition for spinal fusion due to the immediate fixation they provide.

The Medtronic CD HORIZON® M8 Multi Axial Screw System is designed to facilitate the placement of pedicle screws through versatility and ease of use. The multi axial capability provides 28° of freedom in any direction for a total of 56. This multi axial capability allows for easier rod placement and reduction, even when the screws are not perfectly aligned with one another. In addition, the ease of applying compression and distraction enhance the ability to place interbody fusion material.

Other essential features of the M8 Multi Axial Screw System include a buttress thread design, a single locking mechanism and top loading implants. The M8 is a 5.5mm rod system and can be combined with fixed angle screws and hooks, which share the same closure mechanism.

### Multi Axial Screw System Implants

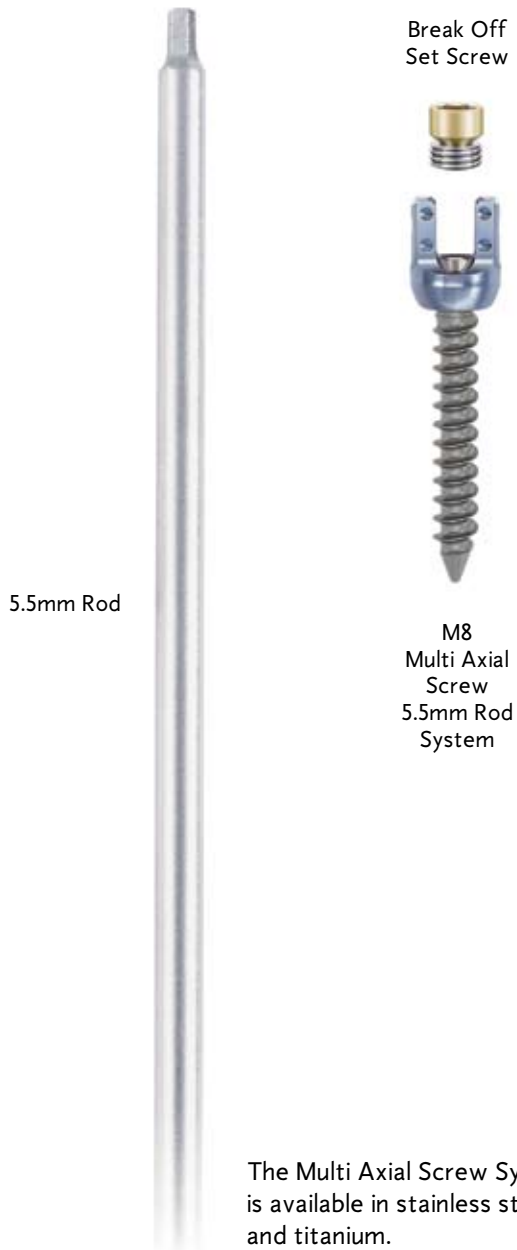

### Low Profile CROSSLINK® Plate Implants

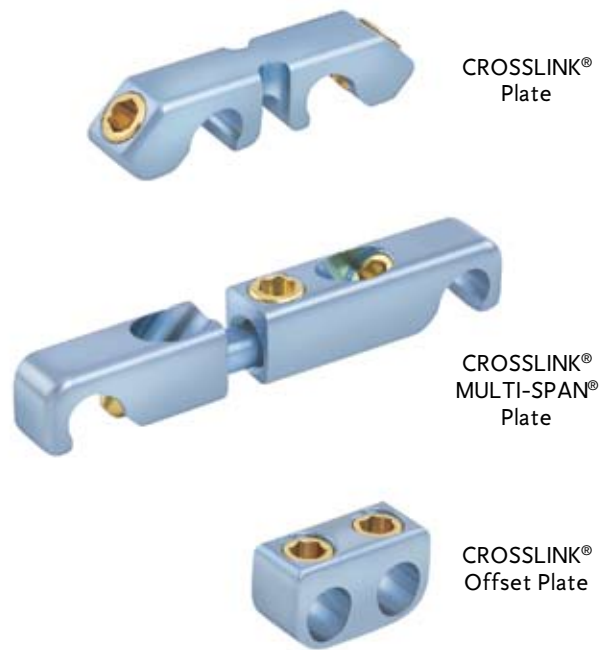

Instrument Set



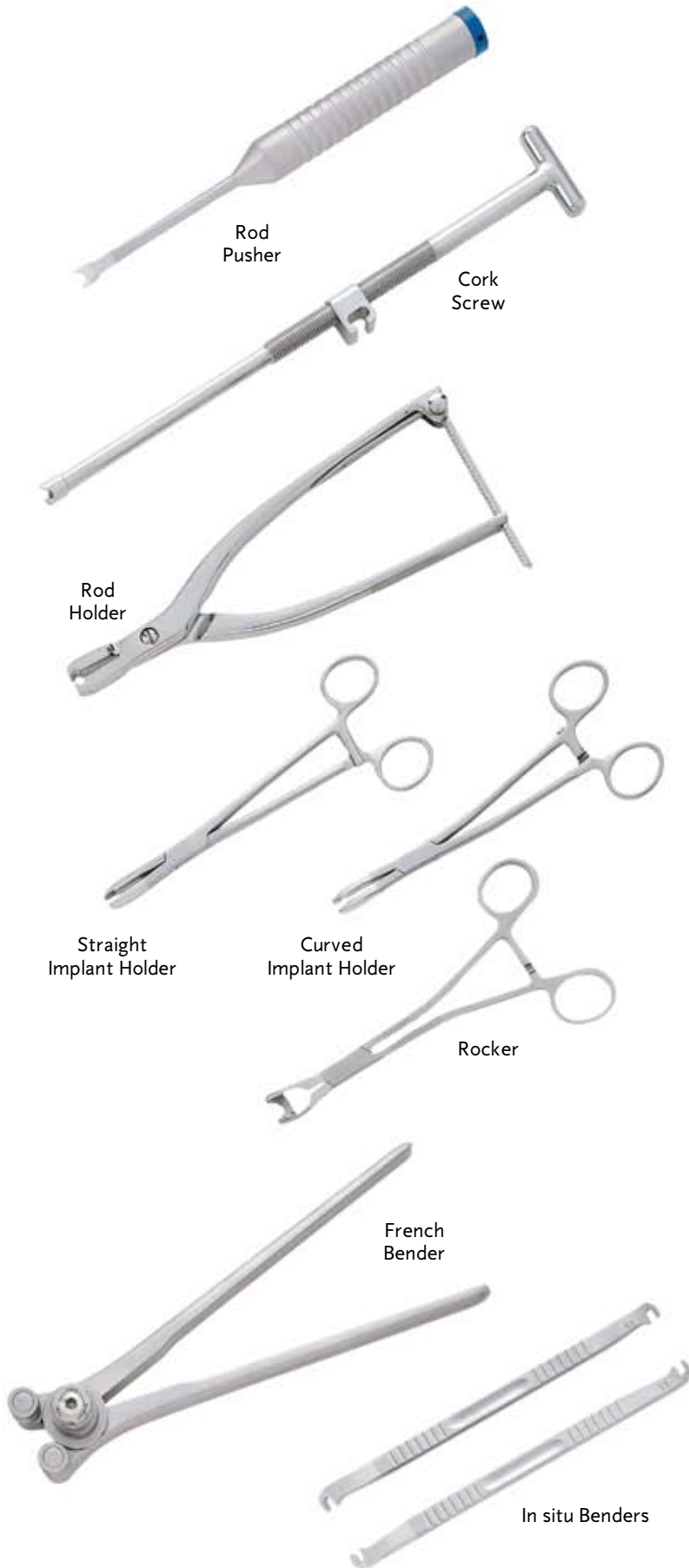

Instruments that may be used with Low Profile CROSSLINK® System



## Multi Axial Screw Insertion

## STEP 1



Fig. 1a

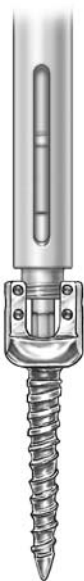

Fig. 1b

With the pedicles prepared and the proper screw lengths determined, the Multi Axial Screws are inserted from L4 to S1, bilaterally, using the Multi Axial Screwdriver (8680052) (Fig. 1a). The hex end of the screwdriver is fully engaged into the screw head. The instrument sleeve is then threaded into the screw head (Fig. 1b). The combination of the hex head and the threaded sleeve provide a stable insertion instrument for driving the Multi Axial Screw.

When fully inserted, the screws should extend 50-80% into the vertebral body and be parallel to the superior endplate (for sacral fixation, especially when bone is osteopenic, bicortical purchase may be utilized).

Once the screw is inserted, the instrument sleeve is unscrewed and disengaged from the screw.



## STEP 2

When necessary, decompression laminectomies are performed to address any stenosis in the central canal, lateral recess and neural foramina. After decompression, Multi Axial Screws can be used to accomplish both anatomic reduction and rigid fixation.

After the insertion of the Multi Axial Screws and prior to inserting the rods, the lordotic alignment of the lumbar spine should be verified via intraoperative lateral X-ray or C-arm. Maintenance of lordosis over the instrumented levels is very important. Prior to rod insertion, extend the hips by adjusting the table to increase lordosis.

Due to differences in pedicle angles, as measured from the sagittal midline, screw position may be misaligned from a posterior view (Fig. 2). Traditional fixation methods required precise bending of the rods to compensate for this; however, the Multi Axial Screw may be angled up to 28° medial and lateral to facilitate placement of the rod (Fig. 3).

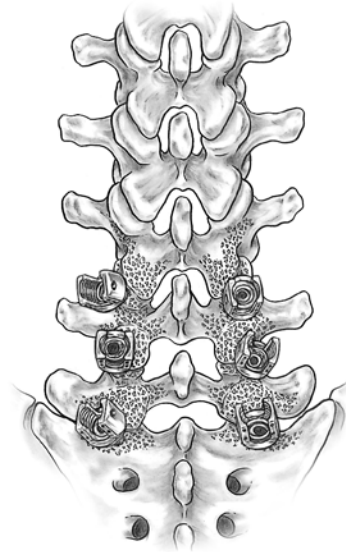

Fig. 2

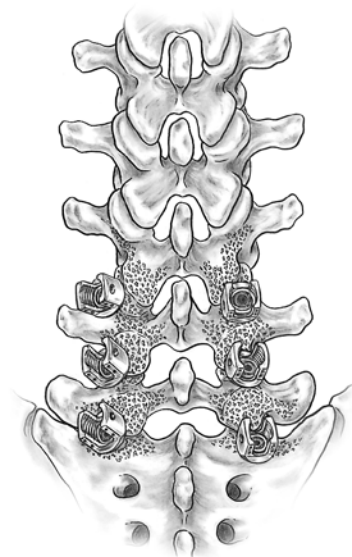

Fig. 3

## Rod Insertion

## STEP 3

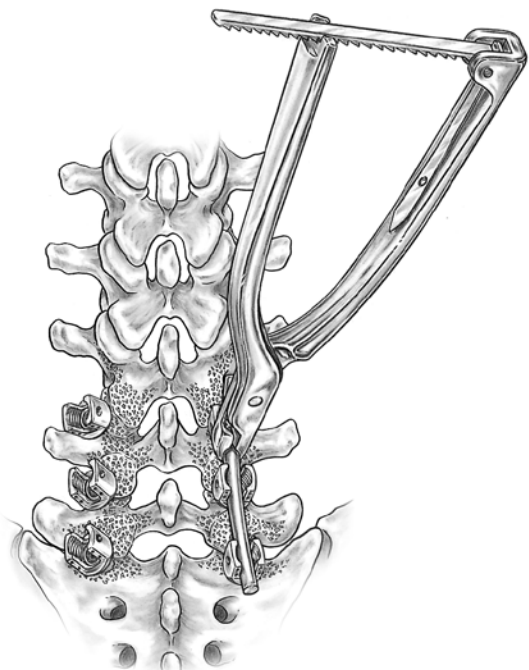

Fig. 4

The rod is placed into the top loading screws beginning from either the cephalad or caudad direction (Fig. 4). The rod is best inserted using a rod gripper (85603).

#### Provisional Implant Closure

With the rod laying in the bottom of the screw head, the break off set screws (hereafter referred to as the "plugs") may be seated into the top of the implant holder using the plug starter (84692E) (Fig. 5 and 5a). To limit the possibility of cross-threading the plug, the plug starter is turned counter clockwise until a "click" is heard. If necessary, the rod may be pushed into the implant using a rod pusher (C6201) or rod reducer II (858-989).

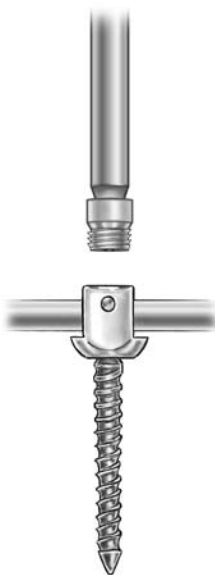

Fig. 5

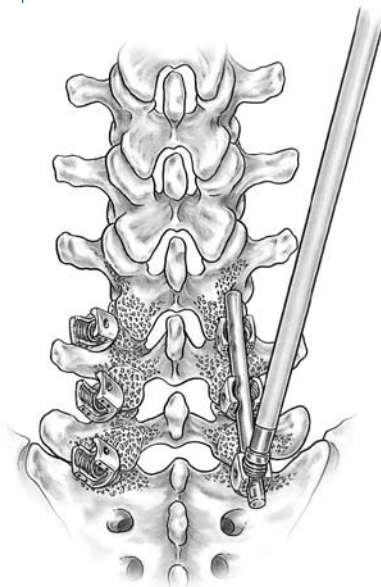

Fig. 5a

## STEP 3

When the rod is not fully seated into the head of the screw, the rocker (815-500) is preferred for reduction (Fig. 6a). The screw head is grasped from either side by the instrument with the rocker cam above the rod. The rocker is then rotated backward levering the rod into the screw head. The plug starter is then used to insert the plug (Fig. 6b).

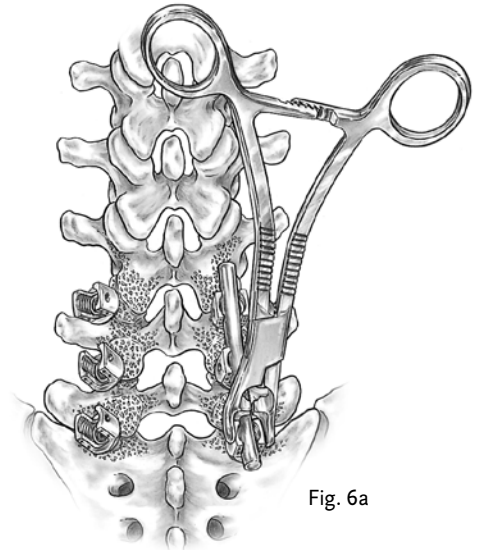

Fig. 6a

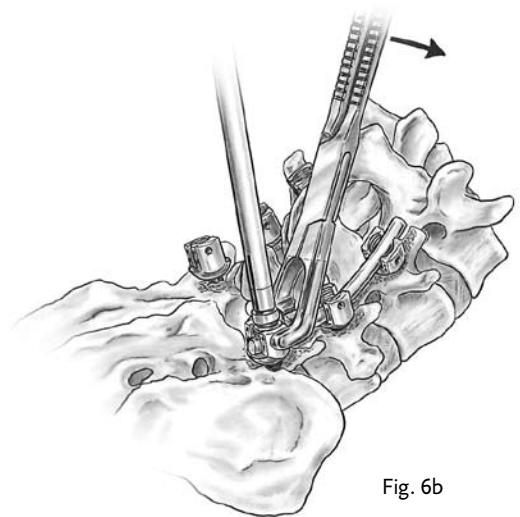

Fig. 6b

## Compression/Distraction

## STEP 4

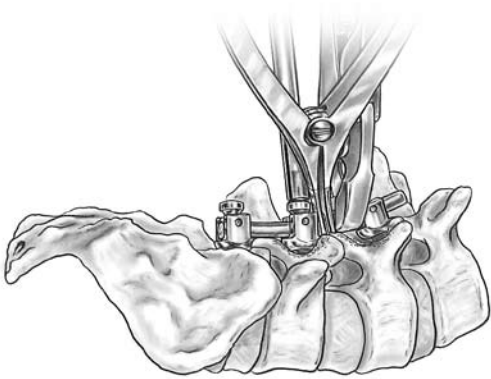

Fig. 7

If compression or distraction is needed, it is carried out at this time. Care should be taken with all plugs to ensure that the feet of either the compressor (94632) or distractor/spreader (94633) are placed securely against the implant body and not against the plug (Fig. 7). Failure to do this may result in slippage of the implant or premature breaking of the plug.

The provisional plug driver (84687E) may be used to maintain temporary locking and security of the rod/implant construct. Usually, temporary fixation of the implant may be performed numerous times without damage to either the plug or implant threads. However, if the plug has been cross-threaded, it must be replaced.

At this point, compression or distraction may be performed. In either maneuver, the plug on one side of the motion segment should be provisionally tightened, with the other plug loose in the implant. Compression or distraction will occur against the provisionally tightened implant. Once satisfactory compression or distraction has been achieved, final tightening may be performed. Distraction is seldom indicated other than while performing a PLIF because of the increased risk of implant breakage, pseudoarthrosis and creating segmental kyphosis.

If it is determined there is inadequate anterior column support, supplemental means to reinforce the anterior column (PLIF) may be performed prior to final tightening of the plugs. When a PLIF is performed, compression should be applied to the posterior rod/screw construct to assure rigid fixation.

## STEP 5

When all implants are securely in place, final tightening and break off of the plug head is done. The appropriate size counter torque device (858-990) is placed over the implant and rod (Fig. 8a) while the tapered hex shaft (815-516) and quick connect handle (836-010) are inserted through the cannulation of the counter torque. The T-handle provides adequate leverage for the break-off of the plug head (between 10-12 N-m for M8). The handle of the counter torque device should be held firmly to prevent torquing of the construct while the plug is secured and sheared off (Fig. 8b).

If desired, the security of the screw/rod interface may be checked after the plug heads have been sheared off by placing a distractor between the screws and applying **moderate** distraction. If motion is present, the plug is either cross-threaded or the rod may not be fully seated in the saddle of the screw. If the plug is cross-threaded, it must be replaced with a new one. If the rod is not fully seated, place the appropriate size counter torque over the head of the screw. The TORX 25 is then used to further tighten the plug until the rod is fully seated in the saddle of the screw.

If necessary, the plug may be removed after final tightening using the TORX 25 shaft (815-518) and quick connect handle (836-010) (Fig. 9). Once a plug has been removed, it should be discarded and replaced with a new one.

NOTE: The appropriate size counter torque device **MUST** be used during final tightening.

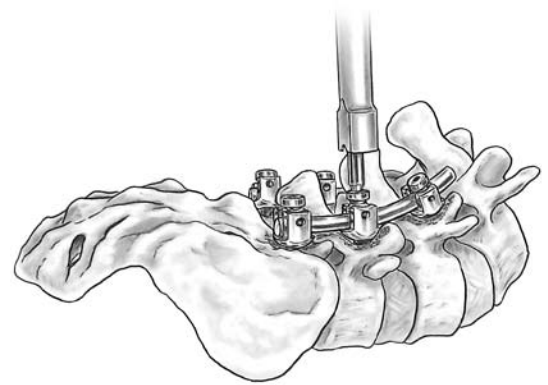

Fig. 8a

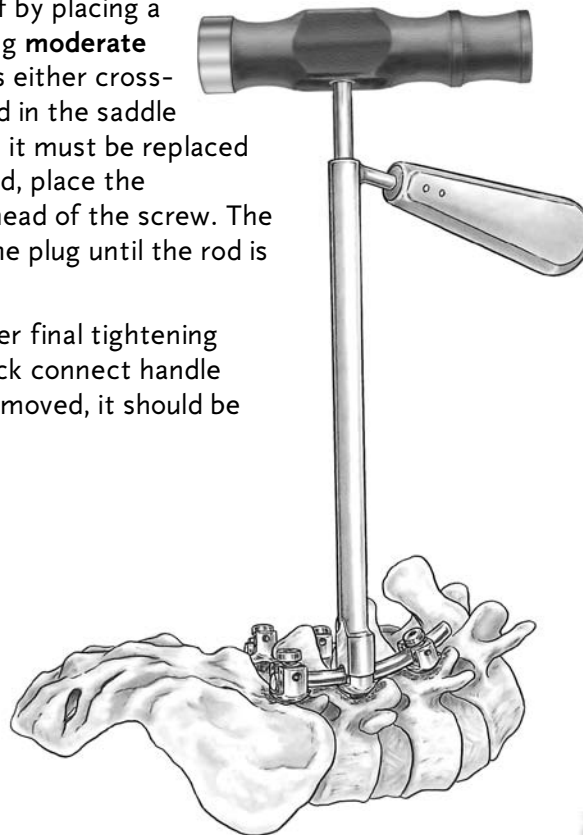

Fig. 8b

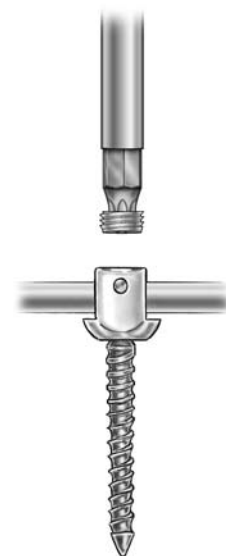

Fig. 9

## Bone Grafting, CROSSLINK® Plate Technique and Closure

## STEP 6

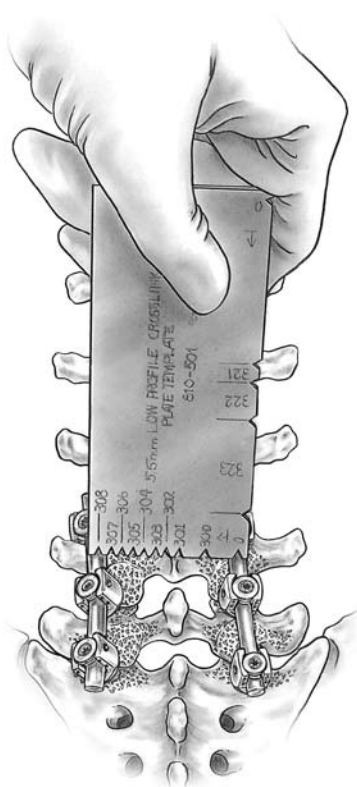

Fig. 10

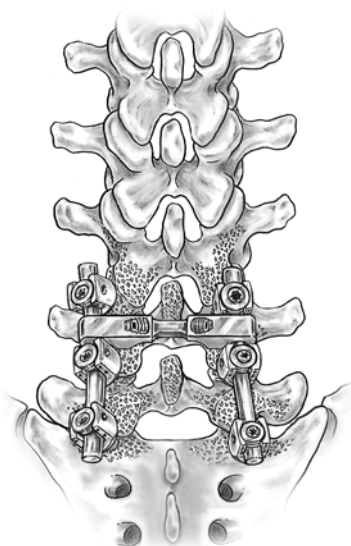

Fig. 11

Decortication and bone grafting can now take place. Low Profile CROSSLINK® Plates may also be added at this time.

Following the final tightening of the screws and rods, the appropriate size Low Profile CROSSLINK® Plate or CROSSLINK® MULTI-SPAN® Plate is determined with the measuring template (Fig. 10). Rods may be spread or compressed as necessary.

With use of the plate holder (810-510), the appropriate Low Profile CROSSLINK® Plate or CROSSLINK® MULTI-SPAN® Plate is selected and pressed down onto the rods (Fig. 11).

Plate benders (810-525) should be used to contour the Low Profile CROSSLINK® Plates or the CROSSLINK® MULTI-SPAN® Plates. When bending the Low Profile CROSSLINK® and CROSSLINK® MULTI-SPAN® Plates, do not exceed 20° in any single plane.

The set screws are advanced using the screwdriver to a torque of approximately 60 in-lbs., alternating tightening from side to side to ensure uniform closure (if using a CROSSLINK® MULTI-SPAN® Plate, the midline screw is tightened after the set screws are secured). Two screwdrivers may be used simultaneously to advance the set screws for uniform closure.

If it is necessary to contour the Low Profile CROSSLINK® MULTI-SPAN® Plate, follow these steps:

- Shorten the telescopic mechanism slightly less than the span between the rods and provisionally tighten the midline set screw.
- Bend the plate as required using the plate benders. However, do not exceed 20° in any single plane.
- Loosen the midline set screw and apply the CROSSLINK® Plate as stated above.

Wound closure is then performed in the customary manner.



## STEP 7

Patients must be warned to avoid physical activities that would place excessive stress upon the implant or bone graft, which could delay or prevent healing. However, regular graduated mild to moderate activity is beneficial to bone formation, particularly when the vertebrae have been adequately stabilized internally. Patients should be instructed in the proper methods of getting in and out of bed, from a sitting position, etc.

Please see the package insert at the end of this brochure for other Warnings, Precautions and Possible Adverse Events about the CD HORIZON® Spinal System.

### Explantation

The plugs (set screws) may be removed using the TORX 25 shaft (815-518) and quick-connect handle (836-010), turning counter-clockwise until the plug has been removed. The pedicle screws may be removed using the Multi Axial Screwdriver (8680052). Fully engage the hex end of the screwdriver into the screw head, then thread the instrument sleeve into the screw head. Turn counter-clockwise until the pedicle screws have been removed.

## Product Ordering Information

## M8 Multi Axial Screws

Titanium	Stainless Steel	Description	Quantity
		<b>M8 Implants</b>	
TMA	SMA	Set Numbers	
8695530	8685530	M8 Multi Axial Screw 5.5 × 30mm	4
8695535	8685535	M8 Multi Axial Screw 5.5 × 35mm	4
8695540	8685540	M8 Multi Axial Screw 5.5 × 40mm	6
8695545	8685545	M8 Multi Axial Screw 5.5 × 45mm	6
8695550	8685550	M8 Multi Axial Screw 5.5 × 50mm	4
8696530	8686530	M8 Multi Axial Screw 6.5 × 30mm	4
8696535	8686535	M8 Multi Axial Screw 6.5 × 35mm	4
8696540	8686540	M8 Multi Axial Screw 6.5 × 40mm	6
8696545	8686545	M8 Multi Axial Screw 6.5 × 45mm	6
8696550	8686550	M8 Multi Axial Screw 6.5 × 50mm	6
8696555	8686555	M8 Multi Axial Screw 6.5 × 55mm	4
8697530	8687530	M8 Multi Axial Screw 7.5 × 30mm	4
8697535	8687535	M8 Multi Axial Screw 7.5 × 35mm	6
8697540	8687540	M8 Multi Axial Screw 7.5 × 40mm	6
8697545	8687545	M8 Multi Axial Screw 7.5 × 45mm	6
8697550	8687550	M8 Multi Axial Screw 7.5 × 50mm	4
8697555	8687555	M8 Multi Axial Screw 7.5 × 55mm	4
859-855	858-855	M8 Break Off Set Screw	30
855-012	845-011	5.5mm Rod, 20"	4
		<b>M8 Cases and Instruments</b>	
170-026	165-026	M8 Multi Axial Screw 4.5/5.0mm Screw Module	1
170-126	165-126	M8 Multi Axial Screw 5.5mm Screw Module	1
170-226	165-226	M8 Multi Axial Screw 6.5/7.5mm Screw Module	1
170-129	165-129	CD HORIZON® M8 Plug Module	1
170-133	165-133	CD HORIZON® M8 Staple/Connector Module	1
n/a	165-143	CD HORIZON® M8 Rod Module	1
8692011	n/a	CD HORIZON® M8 Precut Contoured Rod Module	1
170-046	185-046	M8 Multi Axial Screw Tray Platform	1
170-046	185-046	M8 Multi Axial Screw Tray Platform	1
170-049	185-049	M8 Implant Lid	1

Catalog #	Description	Quantity
800	Set Number	
808-572	8" Rod Template	1
815-516	Tapered Hex Shaft	1
815-517	TORX 20 Shaft	1
815-518	TORX 25 Shaft	1
836-010	Quick Connect Universal Handle	2
84687E	Provisional Plug Driver	1
84692E	Plug/DTT Starter	1
84693E	Plug/Nut Starter	1
858-990	Counter Torque	1
8680052	Multi Axial Screwdriver	1
84799LH	Left In-situ Bender	1
84799RH	Right In-situ Bender	1
858-985	Lateral Implant Holder	2
89690E	Implant Holder Curved Reduced	2

Catalog #	Description	Quantity
89691E	Implant Holder Straight Reduced	1
815-500	Offset Hook Holder/Rocker	1
84683E	Corkscrew	2
858-957	Rod Reducer	1
858-988	Rod Reducer Lever	1
858-989	Rod Reducer II	1
C6201	Rod Pusher	1
808-530	French Bender with Adjustable Cam	1
808-555	Power Grip	1
808-587	Hex Rod Rotation Wrench 3/16"	1
85603	CD 5mm Rod Gripper	1
94632	Hook Compressor	1
94633	Spreader	1
185-201	Instrument Tray #1	1
185-202	Instrument Tray #2	1



## Product Ordering Information

## Low Profile CROSSLINK® Plate

5.5mm Titanium	5.5mm Stainless Steel	Description	Quantity
<b>Implants</b>			
C06	A06	Set Numbers	
811-300	810-300	5.5mm Low Profile CROSSLINK® Offset Plate, L=.375"	2
811-301	810-301	5.5mm Low Profile CROSSLINK® Plate, L=.625"	2
811-302	810-302	5.5mm Low Profile CROSSLINK® Plate, L=.750"	2
811-303	810-303	5.5mm Low Profile CROSSLINK® Plate, L=.875"	2
811-304	810-304	5.5mm Low Profile CROSSLINK® Plate, L=1.000"	2
811-305	810-305	5.5mm Low Profile CROSSLINK® Plate, L=1.125"	2
811-306	810-306	5.5mm Low Profile CROSSLINK® Plate, L=1.250"	2
811-307	810-307	5.5mm Low Profile CROSSLINK® Plate, L=1.375"	2
811-308	810-308	5.5mm Low Profile CROSSLINK® Plate, L=1.500"	2
811-321	810-321	Low Profile CROSSLINK® MULTI-SPAN® Plate, L=1.55"--1.75"	2
811-322	810-322	Low Profile CROSSLINK® MULTI-SPAN® Plate, L=1.75"--2.15"	2
811-323	810-323	Low Profile CROSSLINK® MULTI-SPAN® Plate, L=2.15"--2.95"	2
811-450	810-450	Low Profile CROSSLINK® Plate Set Screw	2
811-451	810-451	Low Profile CROSSLINK® Offset Plate Set Screw	1
<b>Cases and Instruments</b>			
125-166	125-166	Modular Tray with Brackets	1
115-166P	105-166P	Modular Tray Lid Plate	1
115-157	105-157	Mini Module Container (Set Screws)	1
115-150P	105-150P	Tray Plate	1
105-109	105-109	Generic Lid	1
125-128	125-128	Implant Module Lid - CROSSLINK® Plates	1
115-129	105-129	Upper Implant Module	1
115-130	105-130	Lower Implant Module	1
810-501	810-501	Low Profile CROSSLINK® Plate Template	1
810-510	810-510	Low Profile CROSSLINK® Plate Holder	2
810-525	810-525	Low Profile CROSSLINK® Plate Benders	2
803-900	803-900	Hex Head Screwdriver	1

## Important Information on CD HORIZON® Spinal System

### PURPOSE:

The CD HORIZON® Spinal System is intended to help provide immobilization and stabilization of spinal segments as an adjunct to fusion of the thoracic, lumbar, and/or sacral spine.

### DESCRIPTION:

The CD HORIZON® Spinal System consists of a variety of shapes and sizes of rods, hooks, screws, CROSSLINK® Plates, staples and connecting components, as well as implant components from other Medtronic Sofamor Danek spinal systems, which can be rigidly locked into a variety of configurations, with each construct being tailor-made for the individual case.

Certain implant components from other Medtronic Sofamor Danek spinal systems can be used with the CD HORIZON® Spinal System. These components include TSRH® rods, hooks, screws, plates, CROSSLINK® plates, connectors, staples and washer, GDLHTM rods, hooks, connectors and CROSSLINK® bar and connectors; LIBERTY™ rods and screws; DYNALOK PLUS® and DYNALOK® CLASSIC bolts along with rod/bolt connectors; and Sofamor Danek Multi-Axial rods and screws. Please note that certain components are specifically designed to connect to ø3.5mm, ø4.5mm, ø5.5mm rods or ø6.35mm rods, while other components can connect to both ø5.5mm rods and ø6.35mm rods. Care should be taken so that the correct components are used in the spinal construct.

**CD HORIZON® hooks are intended for posterior use only. CD HORIZON® staples and CD HORIZON® ECLIPSE® rods and associated screws are intended for anterior use only. However, for patients of smaller stature, CD HORIZON® 4.5mm rods and associated components may be used posteriorly.**

The CD HORIZON® Spinal System implant components are fabricated from medical grade stainless steel, medical grade titanium, titanium alloy, medical grade cobalt-chromium-molybdenum alloy, or medical grade PEEK OPTIMA-LT1. Certain CD HORIZON® Spinal System components may be coated with hydroxyapatite. No warranties express, or implied, are made. Implied warranties of merchantability and fitness for a particular purpose or use are specifically excluded. See the MSD Catalog for further information about warranties and limitations of liability. **Never use stainless steel and titanium implant components in the same construct.**

Medical grade titanium, titanium alloy and/or medical grade cobalt-chromium-molybdenum alloy may be used together. Never use titanium, titanium alloy and/or medical grade cobalt-chromium-molybdenum alloy with stainless steel in the same construct.

The CD HORIZON® Spinal System also includes anterior staples made of Shape Memory Alloy (Nitinol – NITI). Shape Memory Alloy is compatible with titanium, titanium alloy and cobalt-chromium-molybdenum alloy. **Do not use with stainless steel.**

PEEK OPTIMA-LT1 implants may be used with stainless steel, titanium or cobalt-chromium-molybdenum alloy implants. CD HORIZON® PEEK Rods are not to be used with CROSSLINK® Plates.

To achieve best results, do not use any of the CD HORIZON® Spinal System implant components with components from any other system or manufacturer unless specifically allowed to do so in this or another Medtronic Sofamor Danek document. As with all orthopaedic and neurosurgical implants, none of the CD HORIZON® Spinal System components should ever be reused under any circumstances.

### INDICATIONS:

The CD HORIZON® Spinal System is intended for posterior, non-cervical fixation for the following indications: degenerative disc disease (defined as back pain of discogenic origin with degeneration of the disc confirmed by history and radiographic studies); spondylolisthesis; trauma (i.e., fracture or dislocation); spinal stenosis; curvatures (i.e., scoliosis, kyphosis and/or lordosis); tumor; pseudarthrosis; and/or failed previous fusion.

When used in a percutaneous, non-cervical, posterior approach with the SEXTANT™ instrumentation, the CD HORIZON® screws are intended for the following indications: degenerative disc disease (defined as back pain of discogenic origin with degeneration of the disc confirmed by history and radiographic studies); spondylolisthesis; trauma (i.e., fracture or dislocation); spinal stenosis; curvatures (i.e., scoliosis, kyphosis and/or lordosis); tumor; pseudoarthrosis; and/or failed previous fusion.

Except for hooks, when used as an anterolateral thoracic/lumbar system, CD HORIZON® components such as ECLIPSE® components are intended for the following indications: (1) degenerative disc disease (as defined by back pain of discogenic origin with degeneration of the disc confirmed by patient history and radiographic studies), (2) spinal stenosis, (3) spondylolisthesis, (4) spinal deformities (i.e., scoliosis, kyphosis, and/or lordosis), (5) fracture, (6) pseudarthrosis, (7) tumor resection, and/or (8) failed previous fusion.

The CD HORIZON® SPINOUS PROCESS Plate is posterior, non-pedicle supplemental fixation device, intended for use in the non-cervical spine (T1 – S1). It is intended for plate fixation/attachment to spinous process for the purpose of achieving supplemental fusion in the following conditions: degenerative disc disease - defined as back pain of discogenic origin with degeneration of the disc confirmed by history and radiographic studies; spondylolisthesis; trauma (i.e., fracture or dislocation); and/or tumor.

The CD HORIZON® LEGACY 3.5mm rod and associated components, when used as a pedicle screw fixation system of the non-cervical posterior spine in skeletally mature patients, are indicated for one or more of the following: (1) degenerative spondylolisthesis with objective evidence of neurologic impairment, (2) fracture, (3) dislocation, (4) scoliosis, (5) kyphosis, (6) spinal tumor, and/or (7) failed previous fusion (pseudarthrosis).

In addition, when used as a pedicle screw fixation system, the CD HORIZON® LEGACY 3.5mm rod and associated components, are indicated for skeletally mature patients: (a) having severe spondylolisthesis (Grades 3 and 4) of the fifth lumbar-first sacral (L5-S1) vertebral joint; (b) who are receiving fusions using autogenous bone graft only; (c) who are having the device fixed or attached to the lumbar and sacral spine (L3 and below); and (d) who are having the device removed after the development of a solid fusion mass.

When used as a pedicle screw system in skeletally mature patients, the CD HORIZON® Spinal System PEEK rods and associated components are intended to provide immobilization and stabilization of spinal segments as an adjunct to fusion in the treatment of the following acute and chronic instabilities of the thoracic, lumbar and sacral spine: (1) degenerative spondylolisthesis with objective evidence of neurologic impairment, (2) kyphosis, and/or (3) failed previous fusion. Additionally, when used as a pedicle screw device, the CD HORIZON® Spinal System PEEK rod constructs are indicated for use in patients who: (1) are receiving fusion with autogenous graft only, (2) who are having the device attached to the lumbar or sacral spine, and/or (3) who are having the device removed after the development of a solid fusion mass.

In order to achieve additional levels of fixation, the CD HORIZON® Spinal System rods may be connected to the VERTEX™ Reconstruction System with the VERTEX™ rod connector. Refer to the VERTEX™ Reconstruction System Package Insert for a list of the VERTEX™ indications of use.

### CONTRAINDICATIONS:

Contraindications include, but are not limited to:

1. Active infectious process or significant risk of infection (immunocompromise).
2. Signs of local inflammation.
3. Fever or leukocytosis.
4. Morbid obesity.
5. Pregnancy.
6. Mental illness.

7. Grossly distorted anatomy caused by congenital abnormalities.
8. Any other medical or surgical condition which would preclude the potential benefit of spinal implant surgery, such as the presence of congenital abnormalities, elevation of sedimentation rate unexplained by other diseases, elevation of white blood count (WBC), or a marked left shift in the WBC differential count.
9. Rapid joint disease, bone absorption, osteopenia, osteomalacia and/or osteoporosis.
10. Suspected or documented metal allergy or intolerance.
11. Any case not needing a bone graft and fusion.
12. Any case where the implant components selected for use would be too large or too small to achieve a successful result.
13. Any patient having inadequate tissue coverage over the operative site or inadequate bone stock or quality.
14. Any patient in which implant utilization would interfere with anatomical structures or expected physiological performance.
15. Any patient unwilling to follow postoperative instructions.
16. Any case not described in the indications.

### POTENTIAL ADVERSE EVENTS:

All of the possible adverse events associated with spinal fusion surgery without instrumentation are possible. With instrumentation, a listing of potential adverse events includes, but is not limited to:

1. Early or late loosening of any or all of the components.
2. Disassembly, bending, and/or breakage of any or all of the components.
3. Foreign body (allergic) reaction to implants, debris, corrosion products (from crevice, fretting, and/or general corrosion), including metallosis, staining, tumor formation, and/or autoimmune disease.
4. Pressure on the skin from component parts in patients with inadequate tissue coverage over the implant possibly causing skin penetration, irritation, fibrosis, neurosis, and/or pain. Bursitis. Tissue or nerve damage caused by improper positioning and placement of implants or instruments.
5. Post-operative change in spinal curvature, loss of correction, height, and/or reduction.
6. Infection.
7. Dural tears, pseudomeningocele, fistula, persistent CSF leakage, meningitis.
8. Loss of neurological function (e.g., sensory and/or motor), including paralysis (complete or incomplete), dysesthesias, hyperesthesia, anesthesia, paresthesia, appearance of radiculopathy, and/or the development or continuation of pain, numbness, neuroma, spasms, sensory loss, tingling sensation, and/or visual deficits.
9. Cauda equina syndrome, neuropathy, neurological deficits (transient or permanent), paraplegia, paraparesis, reflex deficits, irritation, arachnoiditis, and/or muscle loss.
10. Urinary retention or loss of bladder control or other types of urological system compromise.
11. Scar formation possibly causing neurological compromise or compression around nerves and/or pain.
12. Fracture, microfracture, resorption, damage, or penetration of any spinal bone (including the sacrum, pedicles, and/or vertebral body) and/or bone graft or bone graft harvest site at, above, and/or below the level of surgery. Retropulsed graft.
13. Herniated nucleus pulposus, disc disruption or degeneration at, above, or below the level of surgery.
14. Non-union (or pseudarthrosis). Delayed union. Mal-union.
15. Cessation of any potential growth of the operated portion of the spine.
16. Loss of or increase in spinal mobility or function.
17. Inability to perform the activities of daily living.
18. Bone loss or decrease in bone density, possibly caused by stresses shielding.
19. Graft donor site complications including pain, fracture, or wound healing problems.
20. Ileus, gastritis, bowel obstruction or loss of bowel control or other types of gastrointestinal system compromise.
21. Hemorrhage, hematoma, occlusion, seroma, edema, hypertension, embolism, stroke, excessive bleeding, phlebitis, wound necrosis, wound dehiscence, damage to blood vessels, or other types of cardiovascular system compromise.
22. Reproductive system compromise, including sterility, loss of consortium, and sexual dysfunction.
23. Development of respiratory problems, e.g. pulmonary embolism, atelectasis, bronchitis, pneumonia, etc.
24. Change in mental status.
25. Death.

**Note:** Additional surgery may be necessary to correct some of these potential adverse events.

### WARNING AND PRECAUTIONS:

**WARNING:** The safety and effectiveness of pedicle screw spinal systems have been established only for spinal conditions with significant mechanical instability or deformity requiring fusion with instrumentation. These conditions are significant mechanical instability or deformity of the thoracic, lumbar, and sacral spine secondary to degenerative spondylolisthesis with objective evidence of neurologic impairment, fracture, dislocation, scoliosis, kyphosis, spinal tumor, and failed previous fusion (pseudarthrosis). The safety and effectiveness of this device for any other conditions are unknown. The implants are not prostheses.

In the absence of fusion, the instrumentation and/or one or more of its components can be expected to pull out, bend or fracture as a result of exposure to every day mechanical stresses.

**PRECAUTION:** The implantation of pedicle screw spinal systems should be performed only by experienced spinal surgeons with specific training in the use of this pedicle screw spinal system because this is a technically demanding procedure presenting a risk of serious injury to the patient.

A successful result is not always achieved in every surgical case. This fact is especially true in spinal surgery where many extenuating circumstances may compromise the results. This device system is not intended to be the sole means of spinal support. Use of this product without a bone graft or in cases that develop into a non-union will not be successful. No spinal implant can withstand body loads without the support of bone. In this event, bending, loosening, disassembly and/or breakage of the device(s) will eventually occur.

Preoperative and operating procedures, including knowledge of surgical techniques, good reduction, and proper selection and placement of the implants are important considerations in the successful utilization of the system by the surgeon. Further, the proper selection and compliance of the patient will greatly affect the results. Patients who smoke have been shown to have an increased incidence of non-unions. These patients should be advised of this fact and warned of this consequence. Obese, malnourished, and/or alcohol abuse patients are also poor candidates for spine fusion. Patients with poor muscle and bone quality and/or nerve paralysis are also poor candidates for spine fusion.

**PHYSICIAN NOTE:** Although the physician is the learned intermediary between the company and the patient, the important medical information given in this document should be conveyed to the patient.

## Important Information on CD HORIZON® Spinal System (Continued)



For US Audiences Only

**CAUTION: Federal law (USA) restricts these devices to sale by or on the order of a physician.**

Other preoperative, intraoperative, and postoperative warnings and precautions are as follows:

**Implant Selection:**

The selection of the proper size, shape and design of the implant for each patient is crucial to the success of the procedure. Metallic surgical implants are subject to repeated stresses in use, and their strength is limited by the need to adapt the design to the size and shape of human bones. Unless great care is taken in patient selection, proper placement of the implant, and postoperative management to minimize stresses on the implant, such stresses may cause metal fatigue and consequent breakage, bending or loosening of the device before the healing process is complete, which may result in further injury or the need to remove the device prematurely.

**Device Fixation:**

**In cases where a percutaneous posterior approach is used refer to the CD HORIZON® SEXTANT™ surgical technique.**

MEDTRONIC SOFAMOR DANEK CD HORIZON® Spinal System instrumentation contains 3.5mm, 4.5 mm, 5.5mm and/or 6.35mm rods and implants, which are intended to be used with device specific instruments.

For self breaking plugs, always hold the assembly with the Counter Torque device. Tighten and break-off the head of the plug to leave the assembly at optimum fixation security. After the upper part of the self breaking plug has been sheared off, further re-tightening is not necessary and not recommended. The head part should not remain in the patient. **AFTER THE UPPER PART OF THE SELF BREAKING PLUG HAS BEEN SHEARED OFF, RE-ADJUSTMENT IS NOT POSSIBLE UNLESS THE PLUG IS REMOVED AND REPLACED WITH A NEW ONE.**

When using DTT Transverse Links, the M6 plug should be tightened to between 8 and 9 Nm. ( 70 to 80 inch-lbs).

CD HORIZON® PEEK Rods are not to be used with CROSSLINK® Plates.

**PREOPERATIVE:**

1. Only patients that meet the criteria described in the indications should be selected.
2. Patient conditions and/or pre dispositions such as those addressed in the aforementioned contraindications should be avoided.
3. Care should be used in the handling and storage of the implant components. The implants should not be scratched or otherwise damaged. Implants and instruments should be protected during storage, especially from corrosive environments.
4. An adequate inventory of implants should be available at the time of surgery, normally a quantity in excess of what is expected to be used.
5. Since mechanical parts are involved, the surgeon should be familiar with the various components before using the equipment and should personally assemble the devices to verify that all parts and necessary instruments are present before the surgery begins. The CD HORIZON® Spinal System components (described in the DESCRIPTION section) are not to be combined with the components from another manufacturer.
6. All components and instruments should be cleaned and sterilized before use. Additional sterile components should be available in case of an unexpected need.

**INTRAOPERATIVE:**

1. Extreme caution should be used around the spinal cord and nerve roots. Damage to the nerves will cause loss of neurological functions.
2. Breakage, slippage, or misuse of instruments or implant components may cause injury to the patient or operative personnel.
3. The rods should not be repeatedly or excessively bent. The rods should not be reverse bent in the same location. Use great care to insure that the implant surfaces are not scratched or notched, since such actions may reduce the functional strength of the construct. If the rods are cut to length, they should be cut in such a way as to create a flat, non-sharp surface perpendicular to the midline of the rod. Cut the rods outside the operative field. Whenever possible, use pre-cut rods of the length needed.
4. Utilize an imaging system to facilitate surgery.
5. To insert a screw properly, a guide wire should first be used, followed by a sharp tap. Caution: Be careful that the guide-wire, if used, is not inserted too deep, becomes bent, and/or breaks. Ensure that the guide-wire does not advance during tapping or screw insertion. Remove the guide-wire and make sure it is intact. Failure to do so may cause the guide wire or part of it to advance through the bone and into a location that may cause damage to underlying structures.
6. **Caution:** Do not overlap or use a screw/bolt that is either too long or too large. Overlapping, using an incorrectly sized screw/bolt, or accidentally advancing the guidewire during tap or screw/bolt insertion, may cause nerve damage, hemorrhage, or the other possible adverse events listed elsewhere in this package insert. If screws/bolts are being inserted into spinal pedicles, use as large a screw/bolt diameter as will fit into each pedicle.
7. Bone graft must be placed in the area to be fused and graft material must extend from the upper to the lower vertebrae being fused.
8. To assure maximum stability, two or more CROSSLINK® plates or DTT Transverse Links on two bilaterally placed, continuous rods, should be used whenever possible.
9. Before closing the soft tissues, provisionally tighten (finger tighten) all of the nuts or screws, especially screws or nuts that have a break-off feature. Once this is completed go back and firmly tighten all of the screws and nuts. Recheck the tightness of all nuts or screws after finishing to make sure that none loosened during the tightening of the other nuts or screws. Failure to do so may cause loosening of the other components.

**POSTOPERATIVE:**

The physician's postoperative directions and warnings to the patient, and the corresponding patient compliance, are extremely important.

1. Detailed instructions on the use and limitations of the device should be given to the patient. If partial weight-bearing is recommended or required prior to firm bony union, the patient must be warned that bending, loosening and/or breakage of the device(s) are complications which may occur as a result of excessive or early weight-bearing or muscular activity. The risk of bending, loosening, or breakage of a temporary internal fixation device during postoperative rehabilitation may be increased if the patient is active, or if the patient is debilitated or demented. The patient should be warned to avoid falls or sudden jolts in spinal position.
2. To allow the maximum chances for a successful surgical result, the patient or devices should not be exposed to mechanical vibrations or shock that may loosen the device construct. The patient should

be warned of this possibility and instructed to limit and restrict physical activities, especially lifting and twisting motions and any type of sport participation. The patient should be advised not to smoke tobacco or utilize nicotine products, or to consume alcohol or non-steroidal or anti-inflammatory medications such as aspirin during the bone graft healing process.

3. The patient should be advised of their inability to bend or rotate at the point of spinal fusion and taught to compensate for this permanent physical restriction in body motion.
4. Failure to immobilize a delayed or non-union of bone will result in excessive and repeated stresses on the implant. By the mechanism of fatigue, these stresses can cause the eventual bending, loosening, or breakage of the device(s). It is important that immobilization of the spinal surgical site be maintained until firm bony union is established and confirmed by roentgenographic examination. If a state of non-union persists or if the components loosen, bend, and/or break, the device(s) should be revised and/or removed immediately before serious injury occurs. The patient must be adequately warned of these hazards and closely supervised to insure cooperation until bony union is confirmed.
5. As a precaution, before patients with implants receive any subsequent surgery (such as dental procedures), prophylactic antibiotics may be considered, especially for high-risk patients.
6. The CD HORIZON® Spinal System implants are temporary internal fixation devices. Internal fixation devices are designed to stabilize the operative site during the normal healing process. After the spine is fused, these devices serve no functional purpose and may be removed. While the final decision on implant removal is, of course, up to the surgeon and patient, in most patients, removal is indicated because the implants are not intended to transfer or support forces developed during normal activities. If the device is not removed following completion of its intended use, one or more of the following complications may occur: (1) Corrosion, with localized tissue reaction or pain; (2) Migration of implant position, possibly resulting in injury; (3) Risk of additional injury from postoperative trauma; (4) Bending, loosening and breakage, which could make removal impractical or difficult; (5) Pain, discomfort, or abnormal sensations due to the presence of the device; (6) Possible increased risk of infection; (7) Bone loss due to stress shielding; and (8) Potential unknown and/or unexpected long term effects such as carcinogenesis. Implant removal should be followed by adequate postoperative management to avoid fracture, re-fracture, or other complications.
7. Any retrieved devices should be treated in such a manner that reuse in another surgical procedure is not possible. As with all orthopedic implants, the CD HORIZON® Spinal System components should never be reused under any circumstances.

**PACKAGING:**

Packages for each of the components should be intact upon receipt. If a loaner or consignment system is used, all sets should be carefully checked for completeness and all components including instruments should be carefully checked to ensure that there is no damage prior to use. Damaged packages or products should not be used, and should be returned to Medtronic Sofamor Danek.

**CLEANING AND DECONTAMINATION:**

Unless just removed from an unopened Medtronic Sofamor Danek package, all instruments and implants must be disassembled (if applicable) and cleaned using neutral cleaners before sterilization and introduction into a sterile surgical field or (if applicable) return of the product to Medtronic Sofamor Danek. Cleaning and disinfecting of instruments can be performed with aldehyde-free solvents at higher temperatures. Cleaning and decontamination must include the use of neutral cleaners followed by a deionized water rinse.

Note: certain cleaning solutions such as those containing formalin, glutaraldehyde, bleach and/or other alkaline cleaners may damage some devices, particularly instruments; these solutions should not be used. Also, many instruments require disassembly before cleaning.

All products should be treated with care. Improper use or handling may lead to damage and/or possible improper functioning of the device.

**STERILIZATION:**

Unless marked sterile and clearly labeled as such in an unopened sterile package provided by the company, all implants and instruments used in surgery must be sterilized by the hospital prior to use. Remove all packaging materials prior to sterilization. Only sterile products should be placed in the operative field. Unless specified elsewhere, these products are recommended to be steam sterilized by the hospital using one of the three sets of process parameters below:

METHOD	CYCLE	TEMPERATURE	EXPOSURE TIME
Steam	Pre-Vacuum	270°F (132°C)	4 Minutes
Steam	Gravity	250°F (121°C)	60 Minutes
Steam*	Pre-Vacuum*	273°F (134°C)*	20 Minutes*
Steam*	Gravity*	273°F (134°C)*	20 Minutes*

NOTE: Because of the many variables involved in sterilization, each medical facility should calibrate and verify the sterilization process (e.g. temperatures, times) used for their equipment. \*For outside the United States, some non-U.S. Health Care Authorities recommend sterilization according to these parameters so as to minimize the potential risk of transmission of Creutzfeldt-Jakob disease, especially of surgical instruments that could come into contact with the central nervous system.

**PRODUCT COMPLAINTS:**

Any Health Care Professional (e.g., customer or user of this system of products), who has any complaints or who has experienced any dissatisfaction in the product quality, identity, durability, reliability, safety, effectiveness and/or performance, should notify the distributor, Medtronic Sofamor Danek. Further, if any of the implanted spinal system component(s) ever "malfunctions", (i.e., does not meet any of its performance specifications or otherwise does not perform as intended), or is suspected of doing so, the distributor should be notified immediately. If any Medtronic Sofamor Danek product ever "malfunctions" and may have caused or contributed to the death or serious injury of a patient, the distributor should be notified immediately by telephone, FAX or written correspondence. When filing a complaint, please provide the component(s) name and number, lot number(s), your name and address, the nature of the complaint and notification of whether a written report from the distributor is requested.

**FOR FURTHER INFORMATION:**

Medtronic B.V.  
Earl Bakkenstraat 10  
6422 PJ Heerlen  
The Netherlands  
Tel: + 31 45 566 80 00



1800 Pyramid Place  
Memphis, TN 38132  
Telephone 800 876 3133 (In U.S.A.)  
901 396 3133 (Outside of U.S.A.)  
FAX 901 396 0356

©2005 MEDTRONIC SOFAMOR DANEK. All rights reserved.

listen. respond. deliver.

The surgical technique shown is for illustrative purposes only. The technique(s) actually employed in each case will always depend upon the medical judgement of the surgeon exercised before and during surgery as to the best mode of treatment for each patient.

Please see the package insert for the complete list of indications, warnings, precautions, and other medical information.

MEDTRONIC  
Spinal and Biologics Business  
Worldwide Headquarters

2600 Sofamor Danek Drive  
Memphis, TN 38132

1800 Pyramid Place  
Memphis, TN 38132

(901) 396-3133  
(800) 876-3133  
Customer Service: (800) 933-2635

[www.sofamordanek.com](http://www.sofamordanek.com)  
For more information go to [www.myspinetools.com](http://www.myspinetools.com)

IRN2319/106  
©2006 Medtronic Sofamor Danek USA, Inc.  
All Rights Reserved.