

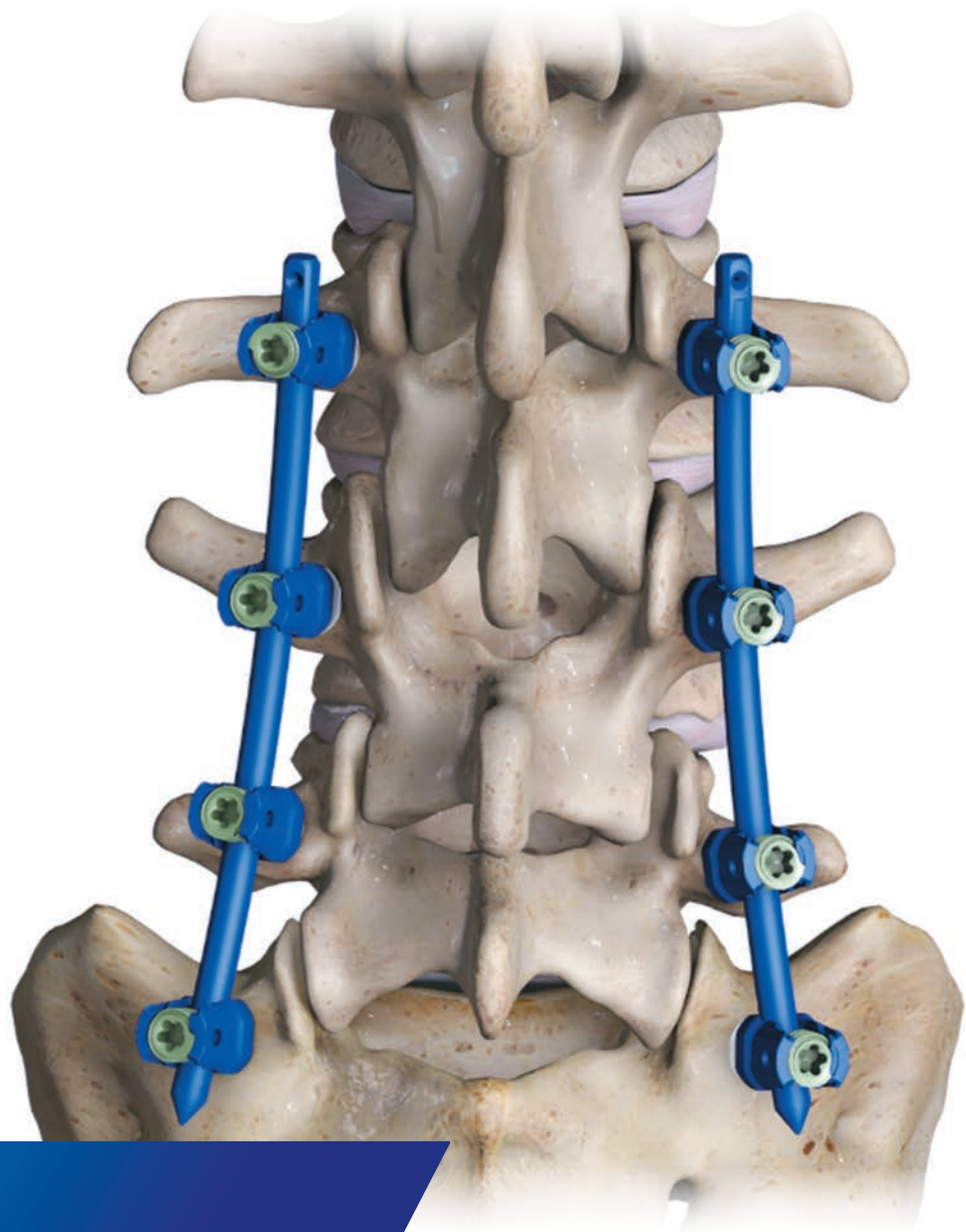

ZIMMER BIOMET

Your progress. Our promise.®



Thoracolumbar Solutions

Cypher™

MIS Screw System

Surgical Technique Guide



Game Changing Technology

- 3 mm of medial-lateral translation encourages optimal screw placement
- Less rod manipulation, easier rod introduction

Unparalleled Thread Performance

- Maximizes screw interaction in various bone densities

TABLE OF CONTENTS

Introduction	4
Features and Benefits	5
Patient Positioning and Pedicle Preparation	6
Pedicle Preparation	7
Pedicle Screw Insertion	9
Rod Insertion	11
Rod Reduction	14
Set Screw Application	16
Compression/Distraction	18
Screw Tower Reattachment	22
Implant Removal	24
Implant and Instruments Kits	25
Implants	28
Instruments	29
Important Information on the Cypher MIS Screw System	33

Zimmer Biomet Spine does not practice medicine. This technique was developed in conjunction with health care professionals. This document is intended for surgeons and is not intended for laypersons. Each surgeon should exercise his or her own independent judgment in the diagnosis and treatment of an individual patient, and this information does not purport to replace the comprehensive training surgeons have received. As with all surgical procedures, the technique used in each case will depend on the surgeon's medical judgment as the best treatment for each patient. Results will vary based on health, weight, activity and other variables. Not all patients are candidates for this product and/or procedure.

INTRODUCTION

The Cypher MIS Screw System, featuring Translation Screw Technology, is a revolution in percutaneous screw procedures. This new technology provides the surgeon with an added level of variability and flexibility, via the translating screw heads. The Translation Screw Technology provides 3 mm of medial-to-lateral variability, to allow the screws to be placed anatomically. The translating screw head will facilitate easier rod passage in a percutaneous fashion.

The Cypher System's instrument set has the singular design rationale of ensuring robust connections to the implants, to instill confidence during these procedures. The screw towers attach to the screws via a simple push motion, with a secondary locking mechanism, to prevent intra-operative release.

The Cypher System is truly a robust combination of intuitive instrumentation and cutting edge implants.

Thread Profile

- Maximizes the screw interaction in various bone densities
- Tactile insertion
- Thread form maximizes bone purchase

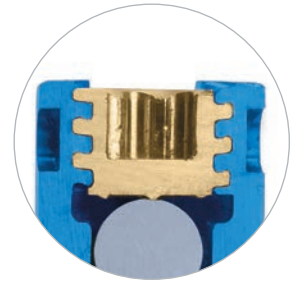

Helical Flange® Technology

Dual-lead Screw Thread

- Faster screw placement
- Balanced insertion

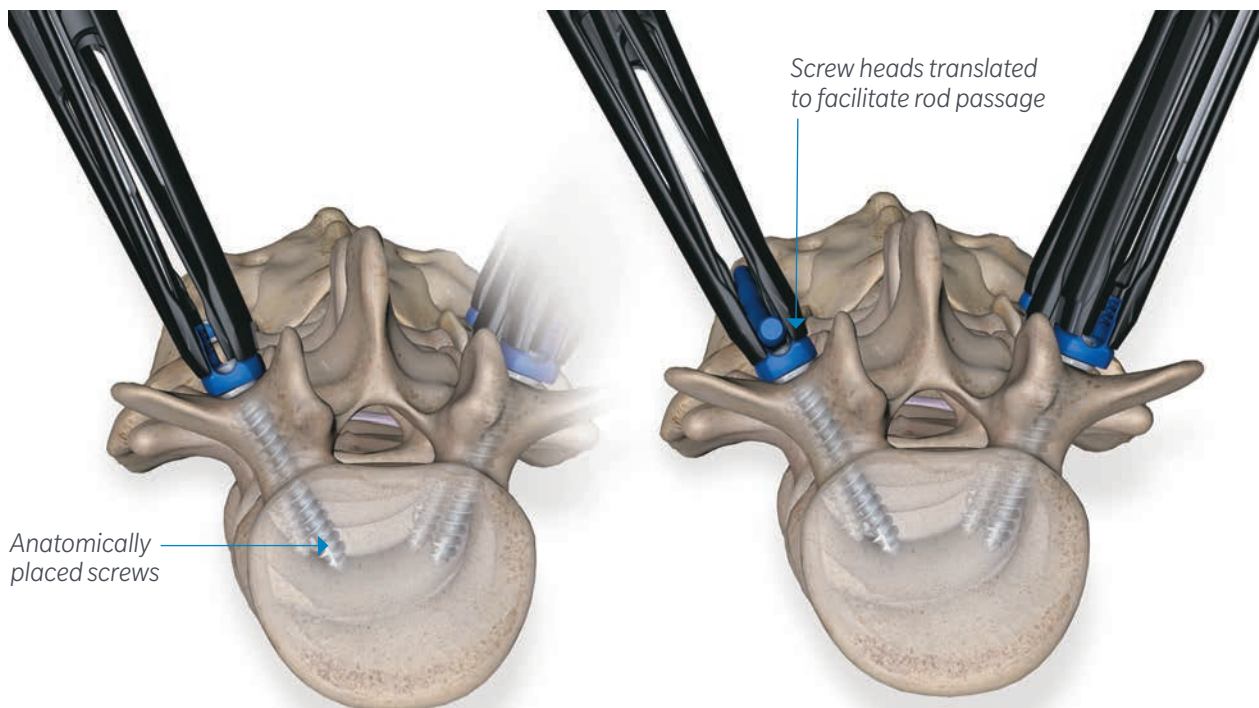

FEATURES AND BENEFITS



FEATURES	BENEFITS
Translation Screw Technology	3 mm of medial-lateral translation relative to the screw shaft Encourages optimal screw placement Less rod manipulation, easier rod introduction
Powerful Rod Reduction	Less rod manipulation, easier rod introduction
Double-lead Thread	Immediate bone engagement
Thread Profile	Fast and efficient screw placement Thread form maximizes bone purchase and performance Constant outer diameter
Friction Fit Seat	Maintains position of screw seat
Helical Flange Technology	Starts easily Minimizes cross threading and seat splay Forces are concentrated inward
Multi-axial Screws	40° of conical angulation for optimum versatility
5.5 mm Rod System	Low profile Anatomical fit
Color-coded Implants	Ease of screw identification



Figure 1

Patient Positioning and Marking

The patient is positioned prone for a posterior approach to the thoracolumbar spine, and then draped in a conventional manner following aseptic techniques.

Utilizing Anterior/Posterior and Lateral fluoroscopic imaging the affected levels are identified and marked on the patient's skin (Figure 1).

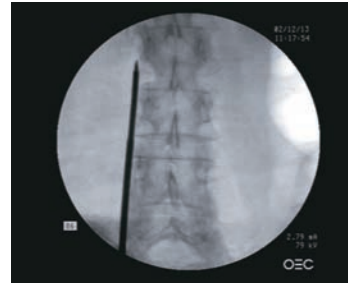

Figure 2

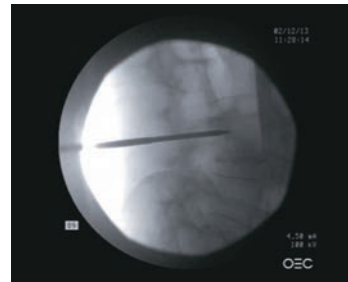

Figure 3

Pedicle Targeting

When visualizing the anatomy, the superior endplates on the A/P radiograph should be parallel, as well as showing perfect symmetry of the pedicles in their relation to the spinous process (Figure 2).

Note: When targeting the S1 Pedicle, a Ferguson view is recommended.

On the lateral radiograph, the endplates and pedicles should be parallel to ensure that the depth trajectory of the instrumentation is in-line with the A/P radiograph (Figure 3).

A spinal needle can be utilized to localize the anatomy and verify the trajectory required for the individual pedicles. Upon confirmation of the trajectory the skin can be marked accordingly for the incision.

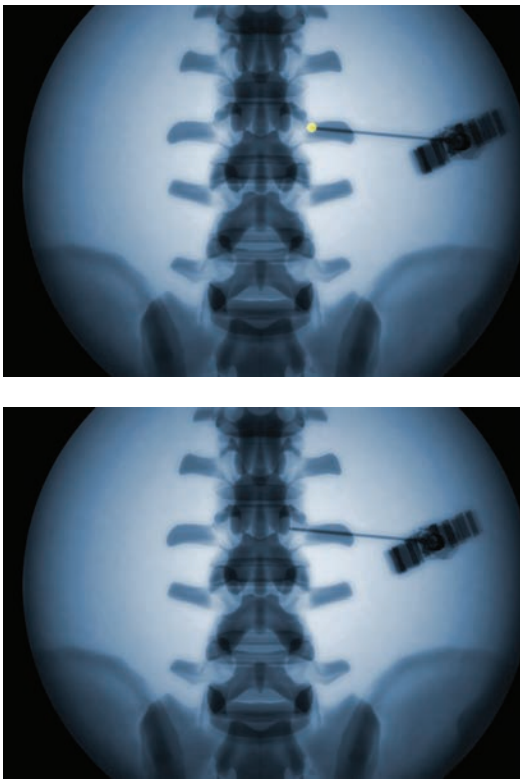

Figure 4

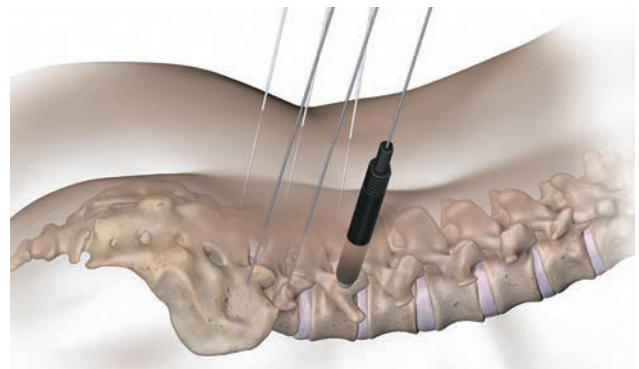

Figure 5

Pedicle Targeting (continued)

- Due to the nature of the pedicle anatomy, care should be taken to ensure that the starting point of the trocar begins in the proper trajectory and plane (Figure 4).
- Skin incision and fascia release of approximately 16 mm is performed and the Jamshidi® needle is advanced.
- From a true A/P view, the proper starting point is at the intersection of the facet and transverse process. On the right side, this is the 3 o'clock position on the lateral wall of the pedicle and on the left side, this is the 9 o'clock position on the lateral wall of the pedicle.
- The pedicle is perforated with the trocar needle and the needle is advanced into the vertebral body following the pedicle trajectory. This trajectory is typically parallel to the endplate with 10 to 12 degrees of lateral to medial angulation.
- Positioning is confirmed using A/P and lateral fluoroscopic imaging.
- Remove the inner trocar from the Jamshidi needle and place the guidewire into the vertebral body.
 - Note:** The guidewire should be placed so that the distal end is approximately 60-70% across the line.
- Remove the needle, taking care that the guidewire maintains purchase in the vertebra.
- Repeat pedicle targeting and preparation for all indicated levels.
- Place the 1st stage dilator over the guidewire, and dock the dilator against the bony anatomy (Figure 5).
- Place the 2nd stage dilator over the 1st stage dilator and dock the dilator against the bony anatomy (Figure 5).
 - Note:** Positioning of the dilator can be confirmed with lateral fluoroscopy.

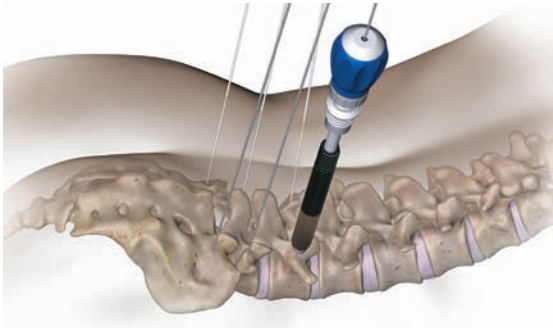

Figure 6

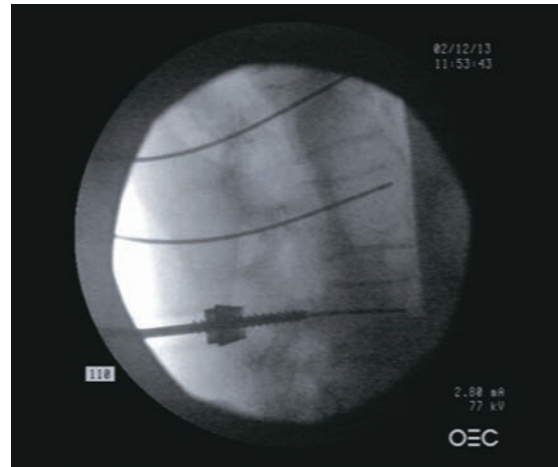

Figure 7

Pedicle Preparation

- Remove the first dilator from the patient.
- Select the appropriate size tap and assemble the tap to the tear drop handle.

Note: *The Cypher System taps are line-to-line with the diameter of the corresponding pedicle screws and it is recommended to tap line-to-line.*
- Place the tap over the guidewire and guide the tap until it is docked against the bony anatomy (Figure 6).
- Turn the handle clockwise to prepare the pedicle until the tap has reached the appropriate depth for the patient (Figure 7).

Note: *Do not tap past the length of the guidewire.*

- Remove the tap from the vertebra by turning the handle counterclockwise until the tap has completely been removed from the pedicle.
- Remove the tap from the dilator, taking care that the guidewire maintains purchase in the vertebra.
- Remove second dilator.
- Repeat the pedicle preparation steps for the subsequent pedicles.



Figure 8

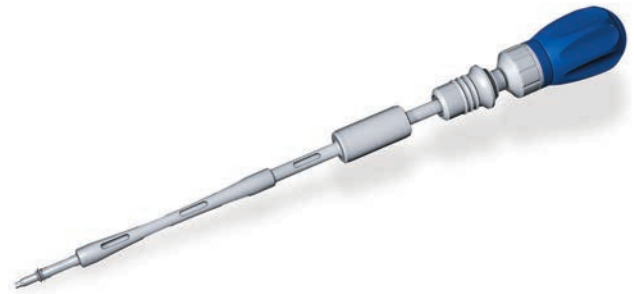

Figure 10



Figure 9

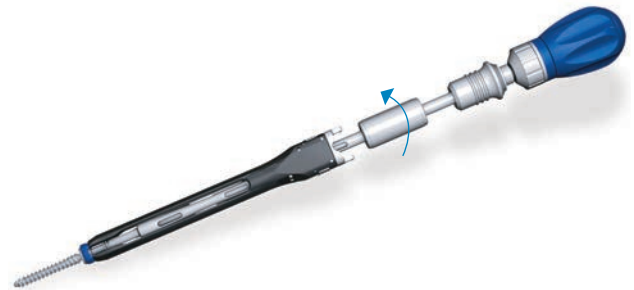

Figure 11

Pedicle Screw Insertion

- Attach the appropriate length and diameter Cypher screw to the screw tower.
 - Ensure that the tabs on the distal end of the screw tower are extended (Figure 8).
 - Align the channel of the screw head to the screw tower and push up until a tactile click is felt.
 - Rotate the collar at the proximal end of the screw tower 90° clockwise to engage the locking mechanism (Figure 9).
 - Assemble the screw inserter to the tear drop handle (Figure 10).
- Guide the assembled screw inserter into the screw tower.
- Align the distal end of the screw inserter into the proximal aspect of the screw shaft and turn the central barrel clockwise until tight (Figure 11).
- Ensure pentalobe drive of screw inserter is engaged in drive of screw.

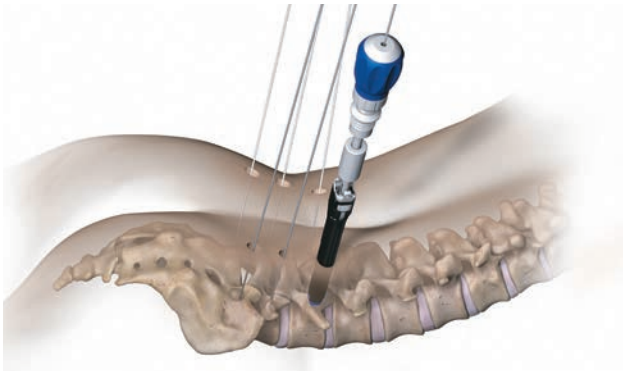

Figure 12a

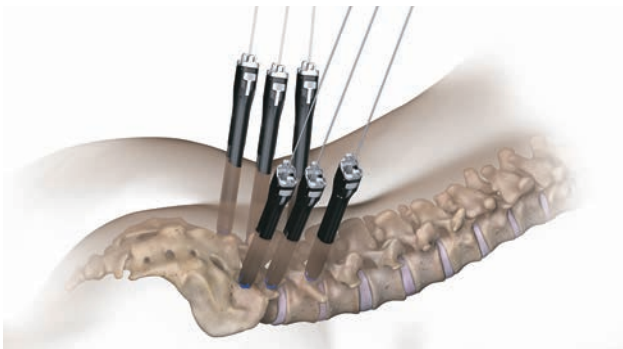

Figure 12b

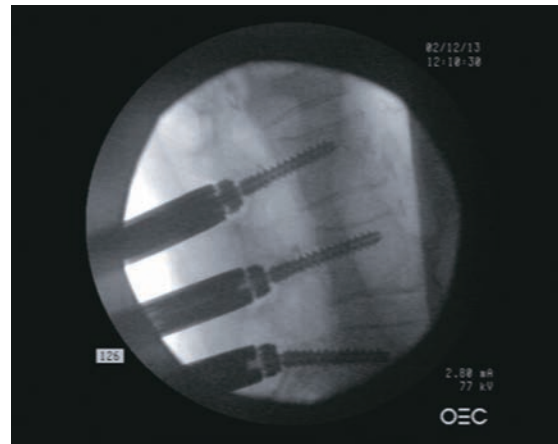

Figure 13

Pedicle Screw Insertion (continued)

- Insert the pedicle screw over the guidewire and push down until the screw is docked against the bony anatomy (Figure 12a).
- Turn the handle clockwise until the pedicle screw has been implanted fully, verify position with lateral fluoroscopic imaging.
- Remove the guidewire
- Remove the screw inserter by turning the central barrel counterclockwise until it has released from the screw head, and pull up out of the screw tower (Figure 12b).
- Verify final positioning with lateral fluoroscopic imaging (Figure 13).
- Repeat the above steps for the subsequent pedicles.



Figure 14

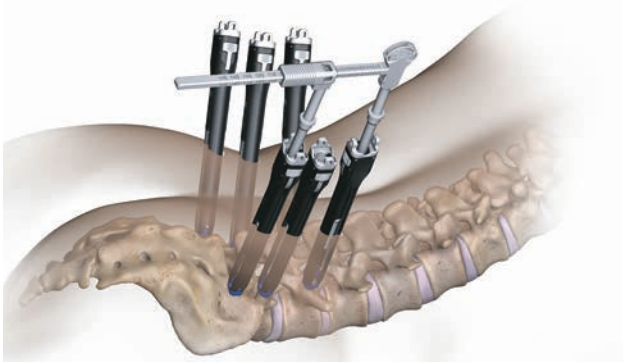

Figure 15

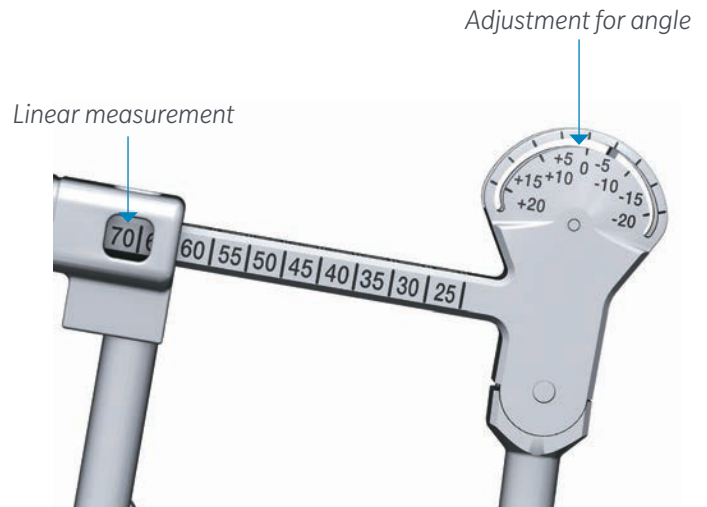

Figure 16

Rod Insertion

Rod Length Determination

- Assemble the rod caliper such that the window for the linear measurement is closest to the scale for angular adjustment (Figure 14).
- Measure the length of the rod by inserting the caliper into the superior and inferior screw towers (Figure 15).
- The caliper provides two readings to determine the actual length of the rod.
 - Linear measurement is determined by the reading along the length of the rack (Figure 16).
 - An adjustment for the length is determined by the reading at the needle on the opposite end of the caliper (Figure 16).
 - Add or subtract the number at the needle from the linear measurement to determine the optimal rod length.
- Contour the rod appropriately for the anatomy and screw placement to facilitate the rod seating into the screw head.



Figure 17



Figure 18

Rod Insertion with Short Rod Inserter

Assembly of the Short Rod Inserter (Figure 17)

- Select the appropriate length rod.
- Align the rod into the distal end of the short rod inserter, ensuring that the lordosis of the rod is facing up when holding the inserter (Figure 18).

Note: The geometry of the rod connection will only allow the rod to be attached in one orientation.

- Secure the rod to the short rod inserter by turning the proximal knob clockwise until tight (Figure 18).

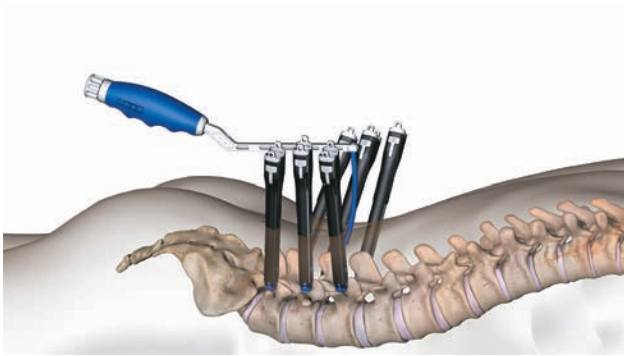

Figure 19

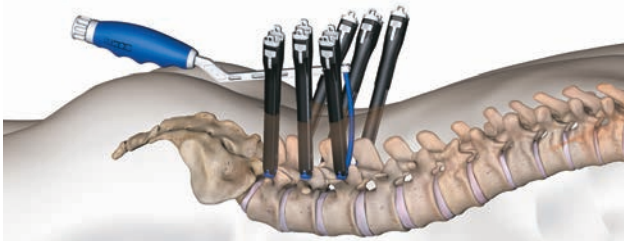

Figure 20

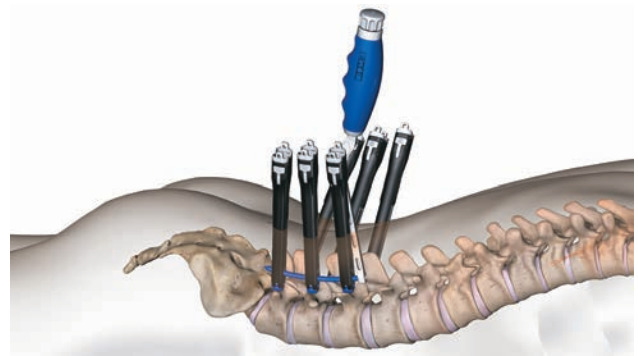

Figure 21

Insertion of the Rod

- Adjust the screw towers so the rod slots are aligned.
- Align the rod inserter to the superior end of the most cephalad screw tower so the rod is in-line with the screw tower (Figure 19).
- Guide the rod down the length of the screw tower and pivot the handle 30° guiding the tip of the rod into the rod slot of the screw tower.
- Continue to guide the rod into the screw tower until the distal end touches the screw head (Figure 20).
- Raise the handle up and pivot the rod towards the distal screw tower until the rod has been passed through all screw tower(s) (Figure 21).

Note: To confirm rod passage, simply try twisting the screw tower. If you feel resistance, the rod is securely inside. If the screw tower can easily twist, the rod is not through the screw tower. Ensure the rod is securely through the screw tower prior to final torquing.



Figure 22



Figure 23

Rod Reduction (optional)

Note: Care should be taken in patients suspected of having osteopenia or osteoporosis when using the powerful rod reducer.

- Upon completion of rod insertion, it may be necessary to utilize the rod reducer to seat the rod within the screw head in order to get the set screw seated properly.
- Assemble rod reducer by sliding the tear drop handle over the proximal end of the rod reducer and fully seat (Figure 22).

Note: The tear drop handle can later be removed to allow additional clearance between towers.

- Prior to inserting the rod reducer into the screw tower, ensure that the instrument is in the starting position with the depth gauge noting 20 at the indication line.
- Guide the rod reducer into the proximal aspect of the screw tower. The distal prongs of the rod reducer are keyed to the tower and can only be inserted in one orientation.
- Push the rod reducer down until it locks into the screw tower. The locking feature of the rod reducer provides the counter force necessary to ensure that the thrust is in a singular direction (Figure 23).
- The rod reducer provides 20 mm of travel. Full reduction is achieved when the black band of the gauge meets the top of the tear drop handle.



Figure 24

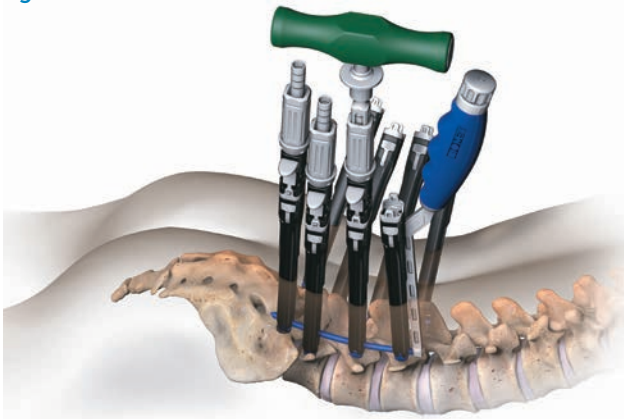

Figure 25

- Load the reduction stabilizer handle onto the reduction instrument to provide counter torque to the tower.
- Turn the handle clockwise until the depth gauge is flush against the top of the handle providing confirmation that a set screw can be placed through the cannulated portion of the instrument (Figure 24)
- If multiple rod reducers are being utilized for sequential rod reduction the tear drop handle can be removed from the instrument and replaced with a reduction adapter to be utilized with the ratcheting handle (Figure 25).



Figure 26



Figure 27

Set Screw Application through Rod Reducer

- Assemble the set screw onto the tear drop plug starter (Figure 26).
- Attach the reduction stabilizer handle to the rod reducer.
- Guide the plug starter down the length of the rod reducer and turn the handle clockwise until the handle has been fully seated (Figure 27).
- Insert and provisionally tighten all set screws in the construct.
- Repeat these steps for the subsequent screws.
- Remove the plug starter from the rod reducer and replace with the torque driver.
- Final tighten the set screws from the distal end of the construct to the proximal end.

Note: Upon confirmation that the set screw has been fully seated within the screw head, turn the tear drop handle on the rod reducer counterclockwise 1/2 turn and pull the silver tabs up to remove the rod reducer from the screw tower.



Figure 28

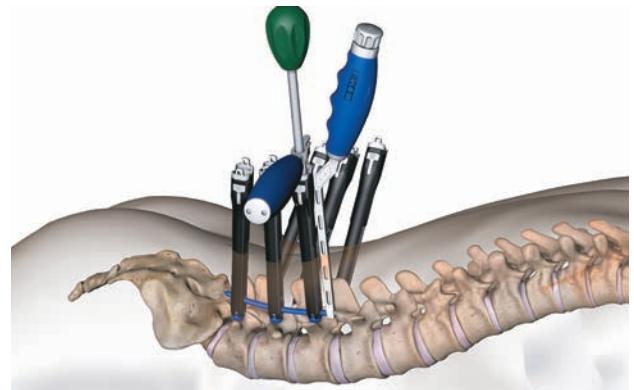

Figure 29

Set Screw Application with Counter Torque

If rod reduction is not necessary, the construct can be definitively tightened with a counter torque and set screws.

- Assemble the set screw onto the tear drop plug starter.
 - Place a counter torque (Figure 28) down the distal screw tower. Proper placement of the counter torque will have the handle being perpendicular to the direction of the rod.
 - Ensure counter torque is fully seated in the screw tower.
- Note:** Individual patient pathology may prevent the rod from being fully seated. Utilize the rod reducer to aid in the seating of the rod.
- Guide the plug starter down the length of the counter torque and turn the handle clockwise until the plug has been fully seated (Figure 29).

- The plug starter has a laser line depicting that the rod is seated fully allowing the plug to be inserted.
- If the plug is not able to be started easily without pressure remove the counter torque and replace with the rod reducer.
- Insert and provisionally tighten all set screws in the construct.
- Repeat the steps for the subsequent screw(s).
- Remove the plug starter from the screw tower, leaving the counter torque in place and replace with the torque driver.
- Final tighten the set screws from the distal end of the construct to the proximal end.

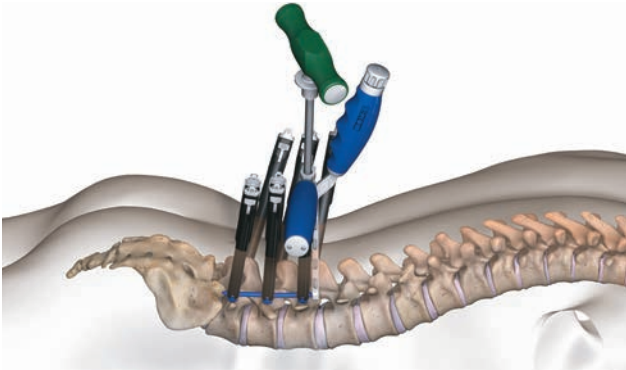

Figure 30

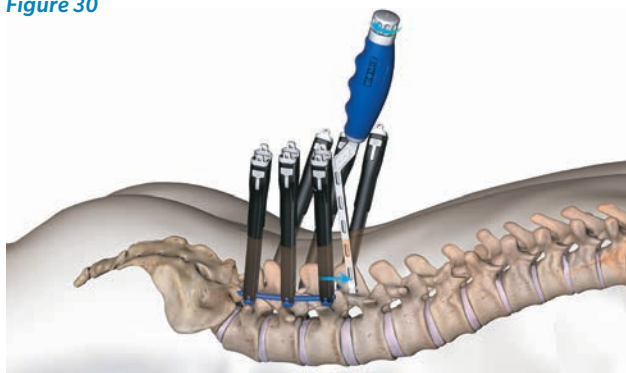

Figure 31

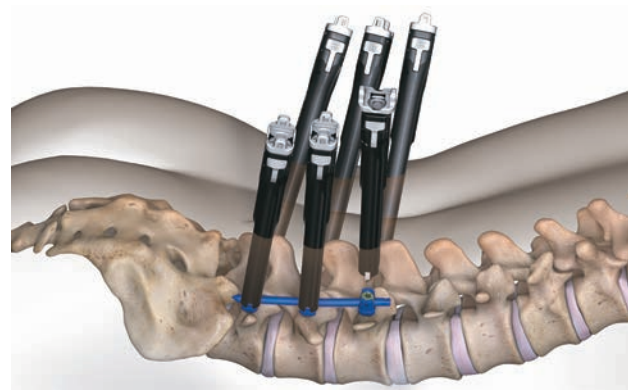

Figure 32

Final Tightening of Set Screws

- Assemble the plug driver to the torque limiting handle.
- Guide the torque driver down the counter torque or rod reducer until the distal end of the instrument is engaged to the set screw.
- Turn the torque handle clockwise until an audible click is heard (Figure 30).

Note: Final torque: 110 in-lbs.

Note: A counter torque or rod reducer must be used when performing final tightening.

- Repeat the above steps for the subsequent screw(s).
- Remove the rod inserter from the rod (Figure 31).
 - Turn the knob on the proximal aspect of the handle counterclockwise until it cannot be turned any further.
 - Pull the handle back from the screw tower, and then up out of the incision.

Tower Removal

- Remove the screw towers from the screw by turning the collar at the proximal aspect of the tower clockwise 90° (Figure 32).
- Simultaneously press the silver buttons on the proximal aspect of the screw tower.
- Lift the screw tower out of the incision.

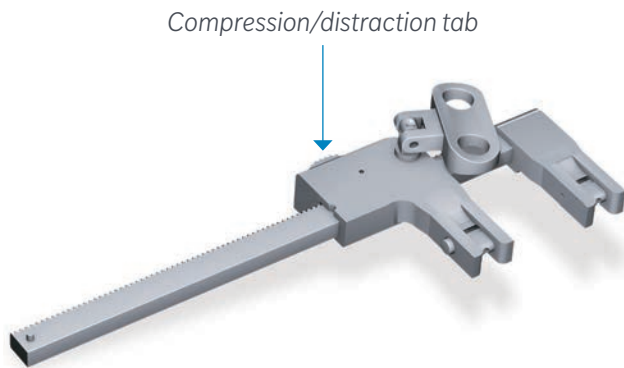

Figure 33



Figure 34

Using the Compressor/Distractor Mechanism

- Upon completion of rod insertion and provisional set screw placement, perform final tightening for one of the set screws.
- Assemble the compressor/distractor mechanism.
 - Place counter torque instruments down the length of the screw towers, ensuring that the attachment features are pointed in the same direction.
 - Slide the tab on the compressor/distractor module (Figure 33) to the neutral position.
 - Guide arms of the compressor/distractor to the attachment feature on the counter torque instruments until fully engaged (Figure 34).

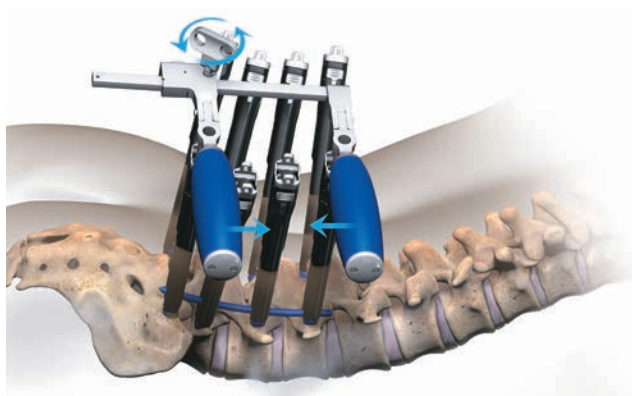

Figure 35

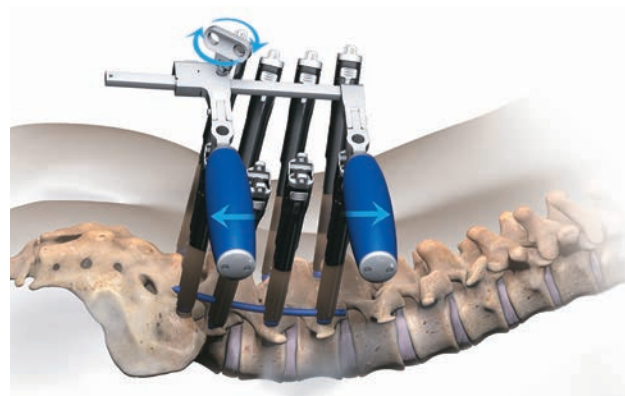

Figure 36

To Perform Compression

- Slide the tab on the compressor/distractor module to compression.
- Turn the wing nut to gain linear compression (Figure 35).
- Perform final tightening of the opposite set screw.
- Remove the compressor/distractor instrument and extensions from the screw towers.

To Perform Distraction

- Slide the tab on the compressor/distractor module to distraction.
- Turn the wing nut to gain linear distraction (Figure 36).
- Perform final tightening of the opposite set screw.
- Remove the compressor/distractor instrument and extensions from the screw towers.



Figure 37

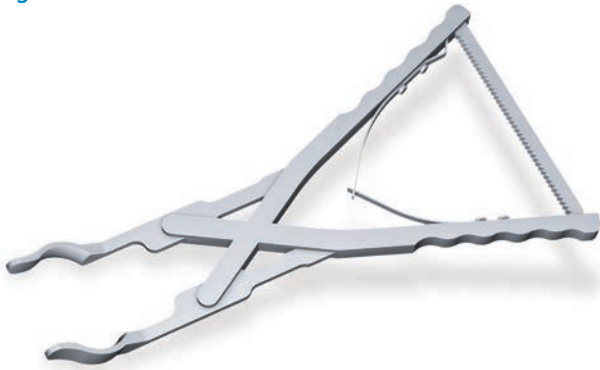

Figure 38



Figure 39

Using the Handheld Compressor/Distractor Instruments

Upon completion of rod insertion and provisional set screw placement, perform final tightening for one of the set screws.

To Perform Compression

- Stabilize the compressor fulcrum (Figure 37) between the screw towers above the level of the skin.
- Place the handheld compressor (Figure 38) **below** the level of the fulcrum at the skin level around the screw towers and squeeze the handle of the compressor until the proper amount of compression is achieved (Figure 39).
- Perform final tightening of the opposite set screw.
- Release the compressor.



Figure 40

To Perform Distraction

- Stabilize the compressor fulcrum between the screw towers at skin level.
- Place the handheld compressor (Figure 38) **above** the fulcrum around the screw towers and squeeze the handle of the compressor until the proper amount of distraction is achieved (Figure 40).
- Perform final tightening of the opposite set screw.
- Release the compressor.

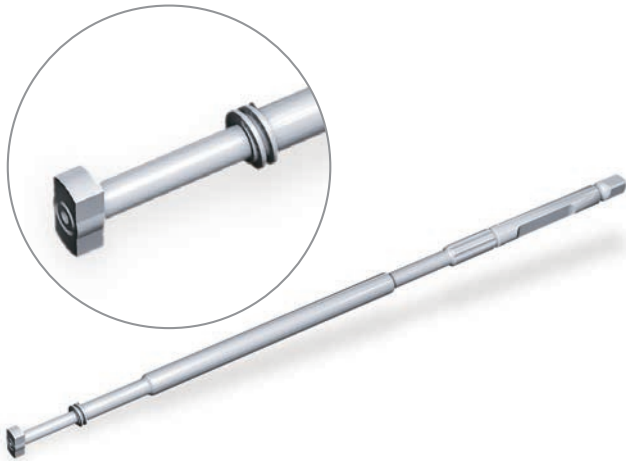

Figure 41



Figure 42

Screw Tower Reattachment Instrument

- Should the screw tower become dissociated from the pedicle screw, utilize the tower reattachment instrument (Figure 41) to re-engage.
 - Guide the distal end of the reattachment instrument into the proximal aspect of the pedicle screw (Figure 42).
 - Upon confirmation of docking, thread the central barrel clockwise to engage the instrument to the screw head.
 - Assemble a counter torque instrument down the length of a screw tower.
- Note:** Ensure that the screw tower is “open” to allow the screw tower to engage the screw head.
- Align the rod slot of the screw tower to be in-line with the direction of the flats as indicated on the reattachment device.
 - Guide the counter torque/screw tower assembly down the length of the reattachment instrument until it is fully seated.
 - Push the screw tower down until it engages the screw head, a tactile click will be felt (Figure 43). Confirm engagement by pulling up on the tower.
 - Remove the counter torque from the screw tower.
 - Engage the locking feature of the screw tower by turning the rotational closure 90°.
 - Remove the reattachment instrument from the screw tower by turning the central barrel counterclockwise until released from the screw head (Figure 44).



Figure 43



Figure 44



Counter Torque
14-501694



Torque Driver Shaft
14-501682



Forceps
14-501657



Torque Wrench Handle
94522



Plug Starter
14-501681



Screw Inserter
14-501801

Implant Removal

The Cypher Implants can be removed by the following method:

Set Screw Removal

- Place a counter torque instrument over the head of the pedicle screw.
- Assemble a torque driver shaft to a fixed t-handle and guide it down the length of the counter torque until it interfaces with the proximal aspect of the set screw.
- Turn the t-handle counterclockwise 1/2 turn to release the set screw but do not fully remove. The torque driver is not a retaining driver.
- Remove the torque driver from the counter torque and replace with a plug starter to fully remove the set screw from the screw head.
- Repeat the above steps for the remaining set screws.
- Remove the rod with a pair of forceps.

Pedicle Screw Removal

- Use the counter torque to align the head with the screw shaft.
 - Place a counter torque over the screw head and align it so that head is co-linear to the orientation of the screw shaft.
 - Remove the counter torque from the screw head.
- Assemble a screw inserter to a tear drop handle.
- Guide the screw inserter to the pedicle screw and tighten the central barrel until it is fully attached to the pedicle screw.
- Turn the screw inserter counterclockwise until the screw has been completely removed from the pedicle.
- Repeat the above steps for the remaining pedicle screws.

Note: Dorsal height adjuster can also be used to remove the pedicle screw.

TECHNICAL SPECIFICATIONS

Cypher System Specifications

INSTRUMENT	SPECIFICATION
Guidewire	1.6 mm x 510 mm Blunt Threaded Nitinol
	1.6 mm x 510 mm Trocar Threaded Nitinol
Rod	ø5.5 mm Titanium
Pedicle Screw Drive	Small Proprietary Pentalobe
Set Screw Drive	Large Proprietary Pentalobe
Rod Reducer Travel	20 mm
Tower Dimensions	A = 12.7 mm B = 16.5 mm C = 17.4 mm



Cypher Screw Specifications

SCREW	SPECIFICATION
Translations	3 mm total travel (1.5 mm from center)
Thread Pitch	2.6 mm (dual lead)

MAJOR Ø	MINOR Ø (Zone 3 - Distance to Taper)	ANGULATION	RUN ON ROD	HEAD HEIGHT	HEIGHT ABOVE ROD
5.5 mm	3.58 mm	40°	11.0 mm	14.6 mm	4.2 mm
6.5 mm	3.89 mm	40°	11.0 mm	14.6 mm	4.2 mm
7.5 mm	4.50 mm	40°	11.0 mm	14.6 mm	4.2 mm

CYPHER MIS SCREW IMPLANT AND INSTRUMENT KITS

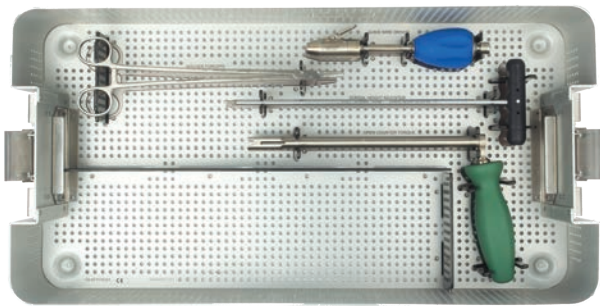
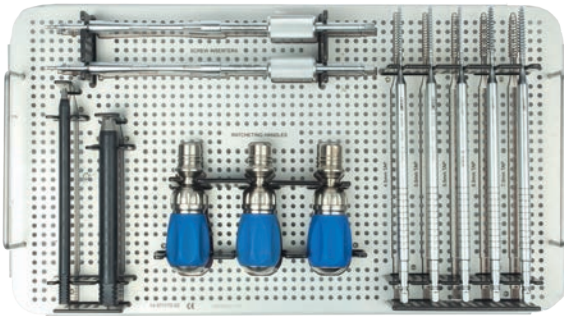

Screw Insertion Instruments Kit Number: 14-571171

DESCRIPTION	QTY	PART NUMBER
Pedicle Preparation Instruments	1	14-571170
1st Stage Dilator	1	14-501675
2nd Stage Dilator	1	14-501676
4.5 mm Tap	1	14-501684
5 mm Tap	1	14-501685
5.5 mm Tap	1	14-501686
6.5 mm Tap	1	14-501687
7.5 mm Tap	1	14-501688
8.5 mm Tap	0	14-501689
Screw Inserter	2	14-501801
Kocher Forceps	1	14-501657
Ratcheting Tear Drop Handle	3	2000-6481
Dorsal Height Adjuster	1	14-501680
Guidewire Driver	1	14-501656
Torque Stabilizer	1	2000-9075

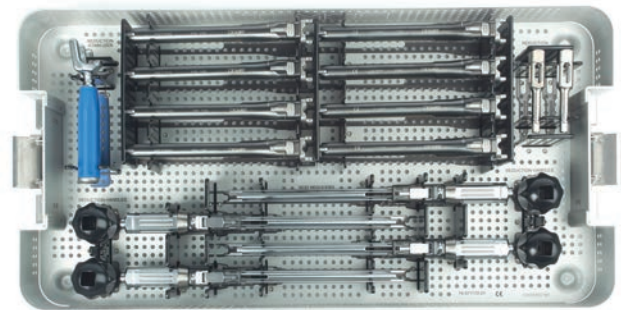

Screw Tower Instruments Kit Number: 14-571173

DESCRIPTION	QTY	PART NUMBER
Screw Tower Instruments	1	14-571172
Cypher Screw Tower	8	14-501692
Cypher Rod Reducer	4	14-501693
Reduction Adapter	2	14-501667
Reduction Stabilizer	1	14-501666
Rod Reducer Handle	4	14-501673

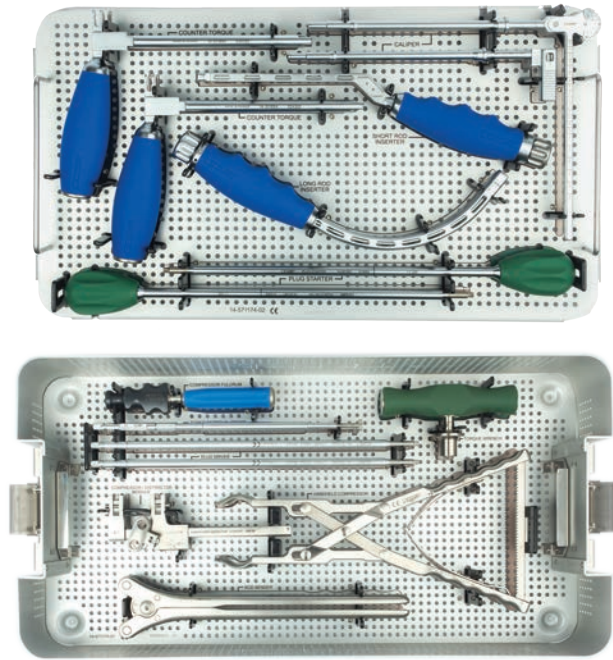

Rod Insertion Instruments
Kit Number: 14-571175

DESCRIPTION	QTY	PART NUMBER
Rod Instrument Tray	1	14-571174
Rod Caliper	1	14-501668
Short Rod Inserter	1	14-501663
Long Rod Inserter	1	14-501664
Cypher Counter Torque	2	14-501694
Compressor/Distractor Assembly	1	14-501670
Handheld Compressor	1	14-501671
Compressor Fulcrum	1	14-501672
Tower Reattachment Device	1	14-501679
Plug Starter	2	14-501681
Torque Driver Shaft	2	14-501682
Rod Bender	1	2000-9044
Torque Wrench	1	94522
Rod Caliper Slider	1	14-501698



Disposable Jamshidi Needle Kit
Kit Number: 14-571181

DESCRIPTION	QTY	PART NUMBER
Needle	8	14-501659

CYPHER MIS SCREW IMPLANT AND INSTRUMENT KITS (continued)



Implants and Instruments Kit Number: 14-571183

DESCRIPTION	QTY	PART NUMBER
5.5 mm x 30 mm Screw	4	14-571330
5.5 mm x 35 mm Screw	4	14-571335
5.5 mm x 40 mm Screw	6	14-571340
5.5 mm x 45 mm Screw	8	14-571345
5.5 mm x 50 mm Screw	6	14-571350
5.5 mm x 55 mm Screw	4	14-571355
5.5 mm x 60 mm Screw	4	14-571360
6.5 mm x 30 mm Screw	4	14-571430
6.5 mm x 35 mm Screw	6	14-571435
6.5 mm x 40 mm Screw	12	14-571440
6.5 mm x 45 mm Screw	12	14-571445
6.5 mm x 50 mm Screw	12	14-571450
6.5 mm x 55 mm Screw	6	14-571455
6.5 mm x 60 mm Screw	4	14-571460
7.5 mm x 30 mm Screw	4	14-571530
7.5 mm x 35 mm Screw	4	14-571535
7.5 mm x 40 mm Screw	6	14-571540
7.5 mm x 45 mm Screw	8	14-571545
7.5 mm x 50 mm Screw	6	14-571550
7.5 mm x 55 mm Screw	4	14-571555
7.5 mm x 60 mm Screw	4	14-571560
30 mm Curved Rod	4	14-571930
35 mm Curved Rod	4	14-571935
40 mm Curved Rod	6	14-571940

DESCRIPTION	QTY	PART NUMBER
45 mm Curved Rod	6	14-571945
50 mm Curved Rod	6	14-571950
55 mm Curved Rod	4	14-571955
60 mm Curved Rod	4	14-571960
65 mm Curved Rod	4	14-571965
70 mm Curved Rod	4	14-571970
75 mm Curved Rod	4	14-571975
80 mm Curved Rod	4	14-571980
85 mm Curved Rod	2	14-571985
90 mm Curved Rod	2	14-571990
95 mm Curved Rod	2	14-571995
100 mm Curved Rod	2	14-571910
110 mm Curved Rod	2	14-571911
120 mm Curved Rod	2	14-571912
130 mm Curved Rod	2	14-571913
140 mm Curved Rod	2	14-571914
150 mm Curved Rod	2	14-571915
250 mm Straight Rod	2	14-571032
400 mm Straight Rod	2	14-571047
510 mm Straight Rod Ti	0	14-571051
5.5 MIS Helical Flange® Ti Set Screw	16	14-500500
Guidewire - Blunt - Nitinol 1.6 mm x 500 mm	16	14-500360
Guidewire - Trocar - Nitinol 1.6 mm x 500 mm	16	14-500361

IMPLANTS



Cannulated Pedicle Screws	PART NUMBER
5.5 mm x 30 mm	14-571330
5.5 mm x 35 mm	14-571335
5.5 mm x 40 mm	14-571340
5.5 mm x 45 mm	14-571345
5.5 mm x 50 mm	14-571350
5.5 mm x 55 mm	14-571355
5.5 mm x 60 mm	14-571360
6.5 mm x 30 mm	14-571430
6.5 mm x 35 mm	14-571435
6.5 mm x 40 mm	14-571440
6.5 mm x 45 mm	14-571445
6.5 mm x 50 mm	14-571450
6.5 mm x 55 mm	14-571455
6.5 mm x 60 mm	14-571460
7.5 mm x 30 mm	14-571530
7.5 mm x 35 mm	14-571535
7.5 mm x 40 mm	14-571540
7.5 mm x 45 mm	14-571545
7.5 mm x 50 mm	14-571550
7.5 mm x 55 mm	14-571555
7.5 mm x 60 mm	14-571560



Curved Rods	Cannulated Pedicle Screws	PART NUMBER
30 mm		14-571930
35 mm		14-571935
40 mm		14-571940
45 mm		14-571945
50 mm		14-571950
55 mm		14-571955
60 mm		14-571960
65 mm		14-571965
70 mm		14-571970
75 mm		14-571975
80 mm		14-571980
85 mm		14-571985
90 mm		14-571990
95 mm		14-571995
100 mm		14-571910
110 mm		14-571911
120 mm		14-571912
130 mm		14-571913
140 mm		14-571914
150 mm		14-571915



MIS Helical Flange® Ti Set Screw 5.5	PART NUMBER
	14-500500



Straight Rods	PART NUMBER
250 mm	14-571032
400 mm	14-571047
510 mm	14-571051*

*Special order item

INSTRUMENTS



Jamshidi® Needle	PART NUMBER
8 Gauge	14-501659



Taps	PART NUMBER
4.5 mm	14-501684
5.0 mm	14-501685
5.5 mm	14-501686
6.5 mm	14-501687
7.5 mm	14-501688
8.5 mm	14-501689*



Guidewire	PART NUMBER
Blunt Threaded - 1.6 mm x 500 mm	14-500360
Trocar Threaded - 1.6 mm x 500 mm	14-500361



Ratcheting Tear Drop Handle	PART NUMBER
	2000-6481



Dilators	PART NUMBER
1st Stage Dilator	14-501675
2nd Stage Dilator	14-501676



Screw Inserter	PART NUMBER
	14-501801

*Special order item



Screw Tower

PART NUMBER

14-501692



Long Rod Inserter

PART NUMBER

14-501664



Short Rod Inserter

PART NUMBER

14-501663



Reduction Adapter

PART NUMBER

14-501667



Rod Reducer

PART NUMBER

14-501693



Reduction Stabilizer

PART NUMBER

14-501666

INSTRUMENTS (continued)



Dorsal Height Adjuster PART NUMBER
14-501680



Rod Caliper PART NUMBER
14-501698



Tower Reattachment Device PART NUMBER
14-501679



Plug Starter PART NUMBER
14-501681



Counter Torque PART NUMBER
14-501694



Compressor/Distractor Assembly PART NUMBER
14-501670



Torque Driver Shaft PART NUMBER
14-501682



Torque Wrench Handle PART NUMBER
110 in-lbs 94522



Rod Bender PART NUMBER
2000-9044



Guidewire Driver PART NUMBER
14-501656



Handheld Compressor PART NUMBER
14-501671



Kocher Forceps PART NUMBER
14-501657



Compressor Fulcrum PART NUMBER
14-501672

IMPORTANT INFORMATION ON THE CYPHER MIS SCREW SYSTEM

Description

The Cypher MIS Screw System is a non-cervical spinal fixation device. The system includes screws, various types and sizes of rods, and plugs. Various instruments are also available for use by the surgeon to facilitate implantation of the device.

Indications for Use

The Cypher MIS Screw System is a non-cervical spinal fixation device intended for immobilization and stabilization as an adjunct to fusion as a pedicle screw fixation system or sacral/ilial screw fixation system for use with autograft and/or allograft. The Cypher Instruments are intended to be used with the Cypher/Polaris™ 5.5 implants. Cannulated screws and percutaneous rods may be used with the Cypher instruments to provide the surgeon with a percutaneous approach for posterior spinal surgery for the following conditions: degenerative disc disease (defined as discogenic back pain with degeneration of the disc confirmed by history and radiographic studies), spondylolisthesis, trauma, (i.e., fracture or dislocation), deformity or curvature (i.e., scoliosis, kyphosis, Scheuermann's disease, and/or lordosis), tumor, stenosis, pseudoarthrosis, and failed previous fusion.

The Cypher MIS Screw System may be used with the instruments in the AccuVision® Minimally Invasive Spinal Exposure System to provide the surgeon with a minimally invasive approach for posterior spinal surgery.

Contraindications

1. Spinal infection.
2. Morbid obesity.
3. A patient who in the surgeon's opinion is not psychosocially, mentally or physically able to fully comply with the post-operative treatment regime (e.g., mental illness, alcoholism or drug abuse).
4. Pregnancy.
5. Metal sensitivity/foreign body sensitivity.
6. Patients with inadequate tissue coverage over the operative site.
7. Open wounds local to the operative area.

Warnings

1. The safety and effectiveness of pedicle screw spinal systems have been established only for spinal conditions with significant mechanical instability or deformity requiring fusion with instrumentation. These conditions are significant mechanical instability or deformity of the thoracic, lumbar, and sacral spine secondary to severe spondylolisthesis (grades 3 and 4) of the L5-S1 vertebra, degenerative spondylolisthesis with objective evidence of neurologic impairment, fracture, dislocation, scoliosis, kyphosis, spinal tumor, and failed previous fusion (pseudoarthrosis). The safety and effectiveness of these devices for any other conditions are unknown. Potential risks identified with the use of this device, which may require additional surgery, include device component fracture, loss of fixation, non-union, fracture of the vertebra, neurological injury, and vascular or visceral injury.
2. **Implant Strength and Loading.** The Cypher MIS Screw System is intended to assist healing and is not intended to replace normal bony structures. Loads produced by weight bearing and activity levels will dictate the longevity of the implant. These devices are not designed to withstand the unsupported stress of full weight bearing or load bearing, and cannot withstand activity levels and/or loads equal to those placed on normal healthy bone. If healing is delayed or does not occur, the implant could eventually break due to metal fatigue. Therefore, it is important that immobilization of the operative site be maintained until firm bony union (confirmed by clinical and radiographic examination) is established. The surgeon must be thoroughly knowledgeable in the medical, surgical, mechanical and metallurgical aspects of the Cypher MIS Screw System. Postoperative care is extremely important. The patient should be warned that noncompliance with postoperative instructions could lead to breakage of the implant and/or possible migration requiring revision surgery to remove the implant.
3. **Selection of Implants.** Selection of the proper size, shape and design of the implant increases the potential for success. While proper selection can help minimize risks, the size and shape of human bones present limitations on the size and strength of implants.
4. **Metabolic bone disease** such as severe osteoporosis may adversely affect adequate fixation of the implants due to the poor quality of the bone.

5. The surgeon must ensure that all necessary implants and instruments are on hand prior to surgery. They must be handled and stored carefully, protected from damage, including from corrosive environments. They should be carefully unpacked and inspected for damage prior to use. All nonsterile components and instruments must be cleaned and sterilized before use.

Biomet Spine implants should not be used with implants or instruments from another manufacturer for reasons of metallurgy, mechanics and design.

6. Corrosion. Contact of dissimilar metals accelerates the corrosion process, which could increase the possibility of fatigue fracture of the implants. Therefore, only use like or compatible metals for implants that are in contact with each other. Never use stainless steel and titanium implant components in the same construct. Cobalt Chrome Alloy rods should not be used with Stainless Steel Components. Cobalt Chrome Alloy rods are to be used ONLY with titanium implant components in the same construct.
7. The Cypher MIS Screw System has not been evaluated for safety and compatibility in the MR environment and has not been tested for heating or migration in the MR environment.
8. The safety and effectiveness of this device has not been established for use as part of a growing rod construct. This device is only intended to be used when definitive fusion is being performed at all instrumented levels.
9. Warning: Direct current stimulation has proven detrimental to the structural integrity of the Cypher MIS Cannulated Translation Screw. As such, a construct that includes the Cypher MIS Cannulated Translation Screw should not come in contact with direct current stimulation devices. Please refer to the Package Insert and/or surgical technique for the proper use of these types of devices.

Limits of System Compatibility

When used with the Cypher Instruments, the use of the cannulated 5.5 screws and percutaneous 5.5 rods is limited to the implantation of rod lengths of 510mm or less, and excludes the use of system cross connectors or hooks. When used with the AccuVision Instruments, it is limited to the implantation of rod lengths of 100mm or less, and excludes the use of system cross connectors or hooks.

Precautions

1. Do not reuse implants/devices. While an implant/device may appear undamaged, previous stress may have created imperfections that would reduce the service life of the implant/device. Do not treat patients with implants/devices that have been even momentarily placed in or used on a different patient.
2. Handling of Implants. If contouring of the rod is required, avoid sharp bends and reverse bends. Avoid notching or scratching of the device, which could increase internal stresses and lead to early breakage.
3. Implant Removal After Healing. After healing is complete, the implant is intended to be removed since it is no longer necessary. Implants that are not removed may result in complications such as implant loosening, fracture, corrosion, migration, pain or stress shielding of bone, particularly in young, active patients. Implant removal should be followed by adequate postoperative management.
4. Adequate Patient Instructions. A patient must be instructed on the limitations of the metallic implant, and should be cautioned regarding physical activity and weight bearing or load bearing prior to complete healing.
5. Surgical Techniques. The implantation of pedicle screw spinal systems should be performed only by experienced spinal surgeons with specific training in the use of pedicle screw spinal systems because this is a technically demanding procedure presenting a risk of serious injury to the patient. Please refer to the specific surgical technique for this device for more information

IMPORTANT INFORMATION ON THE CYPHER MIS SCREW SYSTEM (*continued*)

Possible Adverse Effects

1. Nonunion (pseudarthrosis) fibrous union (pseudarthrosis), delayed union or mal-union.
2. Loss of fixation malfunction, disassembly, pull-out, or bending, fracture, loosening or migration of the implant or instruments.
3. Metal sensitivity or foreign body reaction to implant materials including corrosion by-products due to use of dissimilar implant materials, possible tumor formation, skin or muscle sensitivity in patients with inadequate tissue coverage over the operative site, which may result in skin breakdown and/or wound complications.
4. Decrease in bone density due to stress shielding.
5. Pain, discomfort, or abnormal sensations including back/leg pain due to presence of the implant or surgical procedure.
6. Nerve, soft tissue, or blood vessel damage due to surgical trauma including loss of neurological function, dural tears, radiculopathy, paralysis and cerebral spinal fluid leakage.
7. Gastrointestinal, urological and/or reproductive system compromise, including sterility, impotency and/or loss of consortium.
8. Fracture of bony structures at, above or below the level of surgery (fracture of the vertebra).
9. Nerve root or spinal cord impingement.
10. Bursitis.
11. Necrosis of bone.
12. Hemorrhage of blood vessels, blood clots, and/or hematomas.
13. Malalignment of anatomical structures, including loss of proper spinal curvature, correction, reduction and/or height.
14. Bone graft donor site pain.
15. Inability to resume activities of normal daily living.
16. Neurological, vascular or visceral injury.
17. Reoperation.
18. Infection/sepsis.
19. General surgical complications including cardiac or respiratory issues, exposure to radiation, thrombosis, skin irritation, wound problems, issues related to anesthesia and/or allergic reaction to grafting material.
20. Implant Malposition.
21. Graft Settling/Displacement.
22. Death.

Disclaimer: This document is intended exclusively for physicians and is not intended for laypersons. Information on the products and procedures contained in this document is of a general nature and does not represent and does not constitute medical advice or recommendations. Because this information does not purport to constitute any diagnostic or therapeutic statement with regard to any individual medical case, each patient must be examined and advised individually, and this document does not replace the need for such examination and/or advice in whole or in part.



Caution: Federal (USA) law restricts this device to sale by or on the order of a physician. Rx Only. Please refer to the package inserts for important product information, including, but not limited to, indications, contraindications, warnings, precautions, adverse effects, and patient counseling information.



Manufactured by:
Zimmer Biomet Spine, Inc.
10225 Westmoor Dr.
Westminster, CO 80021 USA
+1 800.447.3625



Zimmer GmbH
Sulzerallee 8
CH-8404 Winterthur
Switzerland
+41 058.854.80.00



ZIMMER BIOMET
Your progress. Our promise.®

800.447.3625 / zimmerbiomet.com

©2018 Zimmer Biomet Spine, Inc. All rights reserved.

All content herein is protected by copyright, trademarks and other intellectual property rights, as applicable, owned by or licensed to Zimmer Biomet Spine, Inc. or its affiliates unless otherwise indicated, and must not be redistributed, duplicated or disclosed, in whole or in part, without the express written consent of Zimmer Biomet Spine. This material is intended for health care professionals, the Zimmer Biomet Spine sales force and authorized representatives. Distribution to any other recipient is prohibited.

Helical Flange® is a registered trademark of Roger P. Jackson. Jamshidi® is a registered trademark of Carefusion 2200, Inc. 2075.1-GLBL-en-REV0918