

VIPER PRIME™ System

Surgical Technique



Contents

Product Overview	Introduction	2
	Features and Benefits	3
	One Tool Screw Insertion	5
Surgical Technique	OR Set Up	6
	Assembly of the VIPER PRIME™ Inserter	8
	Select Screw Length and Load Screw	10
	Load Stylet	10
	Pedicle Targeting	13
	Screw Insertion	15
	Cement Augmentation Procedure for Fenestrated Screws	17
	Rod Measurement and Delivery	18
	Set Screw Insertion	22
	Optional Compression Instructions	24
	Final Tightening	29
	Removal Instructions	31
	Catalog	Instruments
Implants		37
Indications and Contraindications		39

MR Information

This device has not been evaluated for safety and compatibility in the MR environment.
This device has not been tested for heating or migration in the MR environment.

 Image intensifier control

Product Overview

Introduction

Minimally invasive surgical techniques to perform spinal stabilization have gained popularity in recent years due to the demonstration of reduced complications, less blood loss, and less perioperative muscular damage during the procedure.^{1,2} The VIPER PRIME™ System is the next generation of our flagship MIS brand VIPER® System. DePuy Synthes Spine is proud to introduce a novel technique for Percutaneous Pedicle Screw Placement and posterior stabilization. Our innovative technique eliminates the need for guidewires, Jamshidi needles and pedicle preparation instruments. Utilizing a stylet that is fully controlled by the screw driver, surgeons can target pedicles and insert the screw, without the need for instrument exchanges or reconfirmation of their trajectory. This innovation reduces the number of instruments needed, the number of instrument passes and the time required to place a pedicle screw utilizing a minimally invasive technique.³ Surgeons can now realize the benefits of MIS surgery without the need for guidewire management and complex instrument systems.

1. Jhala, Amit, et al. Minimally invasive transforaminal lumbar interbody fusion. *Indian Journal of Orthopaedics* 48(6) (2014 Nov-Dec); 562-567.

2. Peng, Chan Weam Benedict, et al. Clinical and Radiological Outcomes of Minimally Invasive *Versus* Open Transforaminal Lumbar Interbody Fusion. *SPINE* Vol. 34, Number 13 (2009); 1385-1389.

3. ADAPTIV test report 103327910. Bench test results may not necessarily be indicative of clinical performance.

Features and Benefits

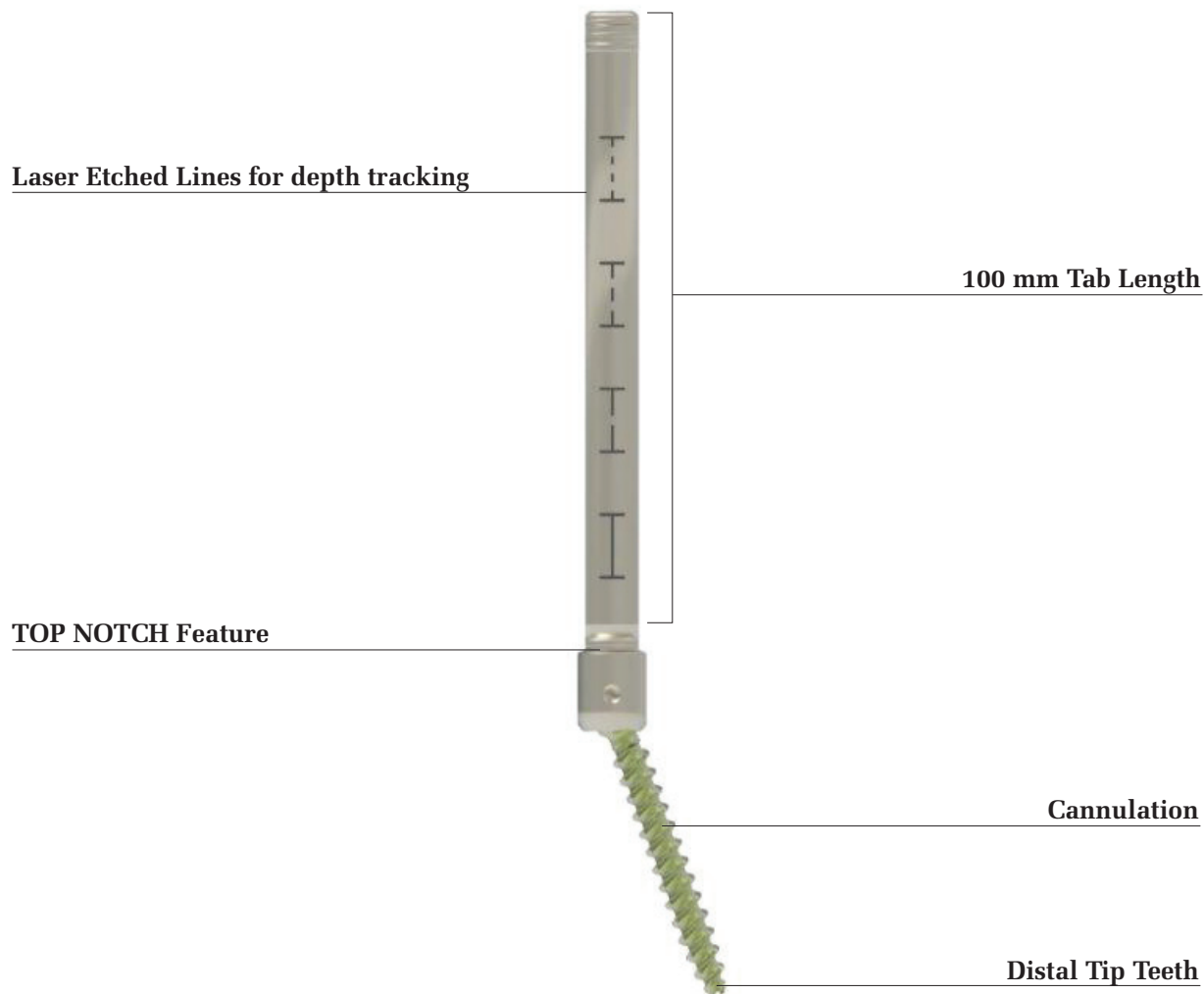
Standard Implant

X-Tab Head

- 100 mm tab length
- Laser etched lines at 10 mm increments to track implant depth relative to the skin
- Proximal threads for driver engagement
- TOP NOTCH® Feature
- Tab strength optimized to enable manipulation without ancillary sleeve

Self-Starting Screw Shank

- Distal tip teeth to enable insertion without pedicle prep (tap or awl)
- X25 drive feature
- Cannulation 1.75 mm diameter



Features and Benefits

Cortical Fix Fenestrated Implant

X-Tab Head

- 100 mm tab length
- Laser etched lines at 10 mm increments to track implant depth relative to the skin
- Proximal threads for driver engagement
- TOP NOTCH Feature
- Tab strength optimized to enable manipulation without ancillary sleeve

Self-Starting Screw Shank

- Distal tip teeth to enable insertion without pedicle prep (tap or awl)
- X25 drive feature
- Cannulation 1.75 mm diameter
- Constant Thread Lead
 - The innovative thread form allows for a smooth transition between the dual and quad lead
- Cortical Thread Form provides enhanced pedicle fixation
- Fenestrations
 - 1.6-1.75 mm fenestration diameters allow for the option of cement delivery for augmented screw fixation

Laser Etched Lines for depth tracking

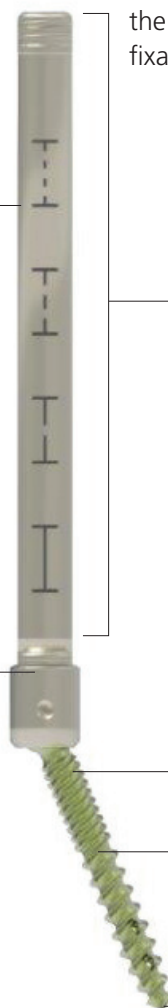
TOP NOTCH Feature

100 mm Tab Length

Cortical Fix Thread Form

Cannulation

Distal Tip Teeth



One Tool Screw Insertion

Stylet

- 1.65 mm diameter Stylet eliminates the need for Jamshidi needles and guidewires
- Trocar style distal tip for docking on & advancing into bone
- The starting point of the Stylet is 3 mm beyond the screw tip to penetrate the cortex and allow for sufficient docking on the posterior bone

Red Stylet Control Handle

- Rotate clockwise to deploy the Stylet. Each audible click represents approximately 1 mm of Stylet advancement
- Hold the red handle during screw advancement to control the Stylet and prevent further forward advancement

Stylet Depth Gauge

- Allows for tracking of the Stylet position. Numbers on gauge indicate the position of the Stylet relative to the tip of the screw

Surgical Technique

Step 1

OR Set-Up

- The patient should be positioned prone lying face down on a radiolucent table. (Fig 1)

Precautions:

It is recommended to use a Jackson Table to assist in achieving the proper patient positioning and an unrestricted fluoroscopic view. Confirm the C-Arm will allow for easy rotation in the lateral, oblique, and A/P positions around the table.

Tables that prohibit unobstructed A/P and lateral images should not be used for this procedure.

Fluoroscopic Planning

- Use A/P and lateral fluoroscopy to identify and target the appropriate level(s). (Fig 2)

Ensure that the C-Arm is positioned correctly for each targeted level by adjusting the position of the C-Arm until both endplates are parallel and the spinous process is equidistant from the center of each pedicle when viewed on A-P fluoroscopy.

The C-Arm may need to be repositioned for each appropriate level.

Fig 1

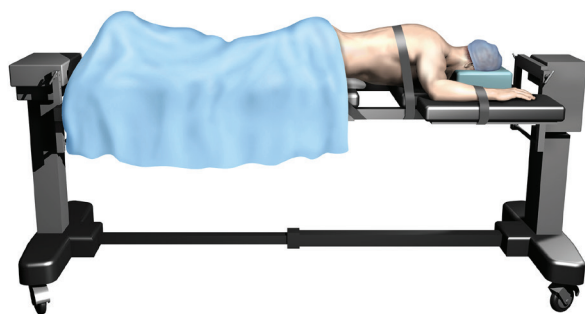
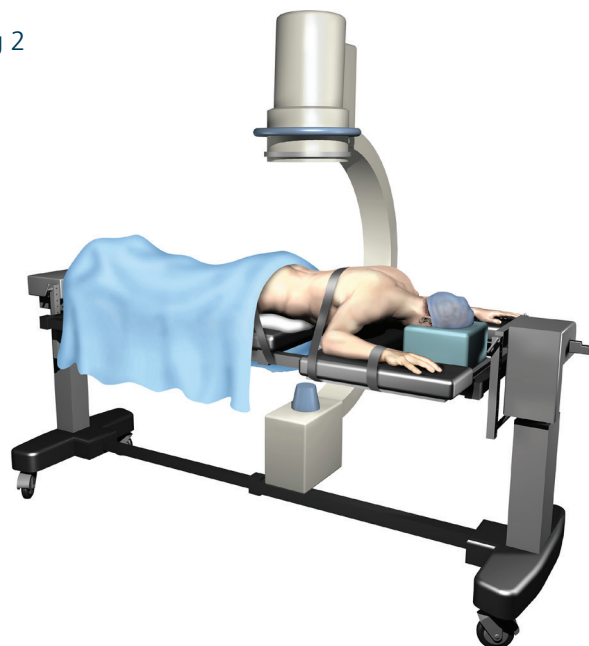


Fig 2

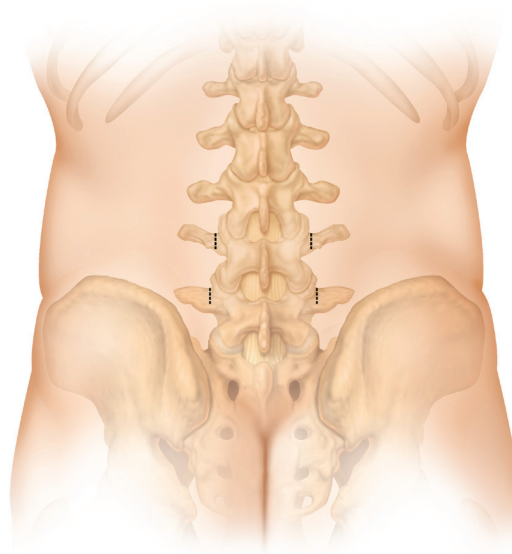


Determine the Skin Incision Location

- Place a guidewire on the patient perpendicular to the axis of the spine at the targeted level. Using A-P fluoroscopy, position the guidewire such that its projection transects the center of both pedicles in the cephalad-caudal direction. Use a surgical marker to transfer that plane to the patient. (Fig 3)
- Place guidewires on the patient parallel to the axis of the spine. Using A-P fluoroscopy, position the guidewire such that its projection aligns to the lateral pedicle wall of the targeted level and the adjacent levels. The lateral pedicle wall of adjacent levels may also be estimated at this time. Use a surgical marker to transfer this plane onto the patient.

The longitudinal skin incision for each level should be at least 1 cm lateral to the intersection of the two lines. This distance may vary depending on size of the patient.

Fig 3



Step 2

Assembly of the VIPER PRIME Inserter

The Inserter is made up of 4 components:

1. Carrier (Fig 4)
2. Drive Tube (Fig 5)
3. Red Stylet Control Handle (Fig 6)
4. Shaft (Fig 7)

Fig 4

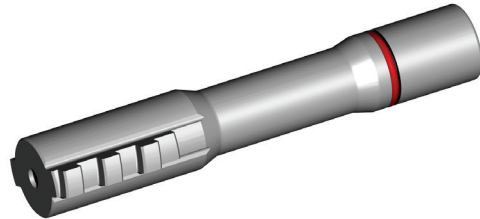


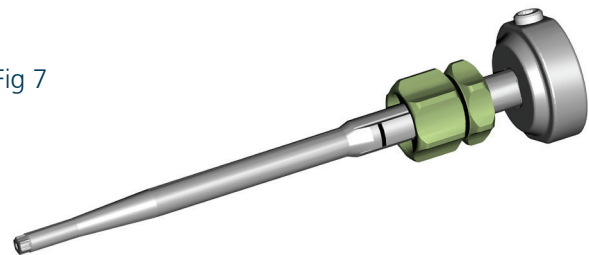
Fig 5



Fig 6

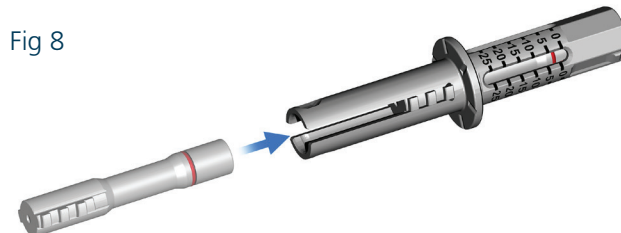


Fig 7

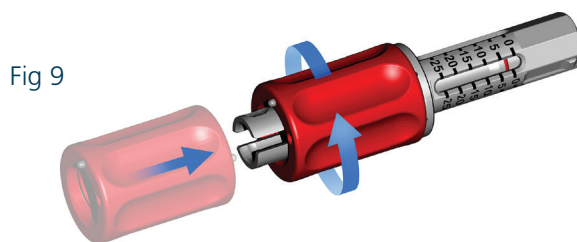


Assembly of the VIPER PRIME Inserter (continued)

- Insert the Carrier into the Drive Tube with the red line indicator facing into the tube. (Fig 8)

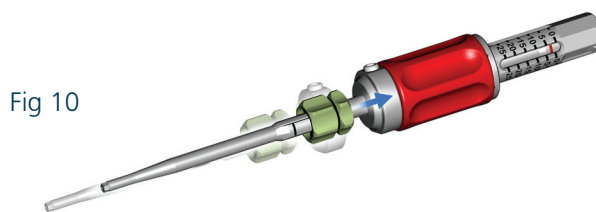


- Thread the Red Stylet Control Handle over the Carrier until it is seated on the Drive Tube. This is a reverse thread and should be rotated counterclockwise to assemble. (Fig 9)

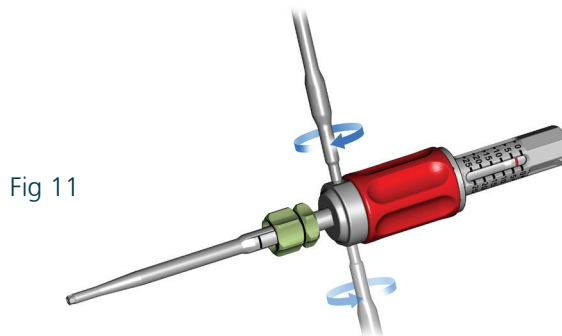


- Insert the tabs of the Drive Tube into the Shaft. (Fig 10)

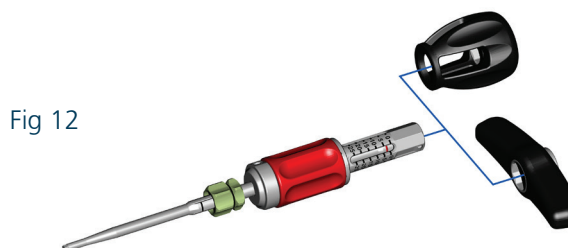
Ensure that the two set screws on the sides of the Shaft are fully backed out before trying to attach the Drive Tube. You will hear an audible click when the Drive Tube properly snaps into place.



- Using the Set Screw Driver, hand-tighten both set screws on the Inserter Shaft. (Fig 11)



- Select a VIPER PRIME Modular Handle (T-handle or Palm) and attach to the proximal end of the Inserter. These will snap into place over the spring tabs of the Drive Tube. (Fig 12)



The Modular Handle may be removed at any time for visualization.

Step 2a

Select Screw Length and Load Screw

- Select the screw size (length and diameter) based on pre-operative imaging and planning and load onto the VIPER PRIME Inserter. Ensure that the Inserter is fully seated in the screw drive feature, and then tighten the green knob to the proximal threads on the screw tabs to secure the implant. The Inserter tip can strip if the Inserter is not fully seated during screw insertion. (Fig 13)

The dark etch line on the Inserter Shaft should line up with the most proximal etch line on the X-Tab. This ensures that the shaft drive feature is fully engaged with the implant screw shank.

Fig 13

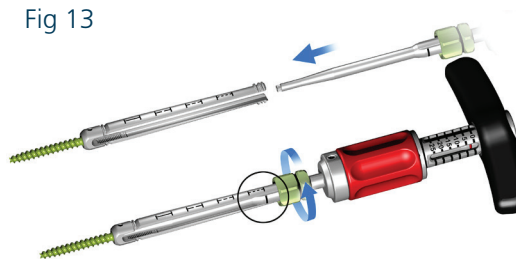
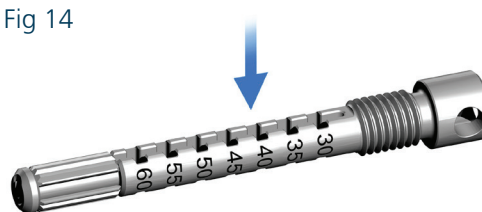


Fig 14



Step 2b

Load Stylet

- On the Stylet Depth Adjustor, identify the slot that corresponds to the chosen screw length. (Fig 14)
- Remove the Stylet from sterile packaging.

Ensure that the slot on the retaining sleeve is rotated into the "Open" position so that the slots are aligned. (Fig 15)

- Insert the distal tip of the Stylet through the distal ring on the Depth Adjustor and place the proximal flange of the Stylet in the slot for the identified screw length. (Fig 16)

Fig 15



Fig 16



Load Stylet continued

- Rotate the retaining sleeve on the Depth Adjustor 180 degrees to capture the stylet and make sure it is properly retained. (Fig 17)
- Insert the Stylet and the Depth Adjustor into the top of the VIPER PRIME Inserter. (Fig 18)
- Use the X25 Set Screw Driver to thread the Depth Adjustor into the assembled Inserter until it is fully seated. (Fig 19)

It is recommended to use a Modular Handle at this point to provide countertorque during Depth Adjustor insertion.

- Turn the Red Stylet Control Handle counterclockwise until it stops to fully retract the Stylet. Confirm that the Stylet tip extends approximately 3 mm beyond the distal tip of the screw in this position as indicated by the red line visible through the drive tube window on the Stylet Depth Gauge. (Fig 20)

Precaution: If the Stylet is not visible beyond the screw tip or you cannot retract it to 3 mm, disassemble the Depth Adjustor and confirm that the stylet flange is seated in the appropriate screw length slot.

The Stylet can be extended to a maximum of 25 mm beyond the tip of the screw.

Consider a traditional Jamshidi and guidewire technique if the Stylet cannot be advanced or retracted using the Red Stylet Control Handle at any point in the procedure.

Fig 17



Fig 18



Fig 19

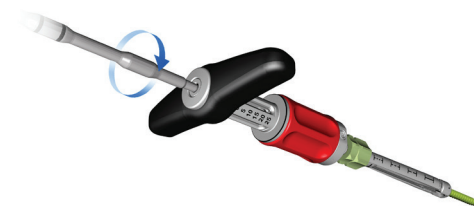
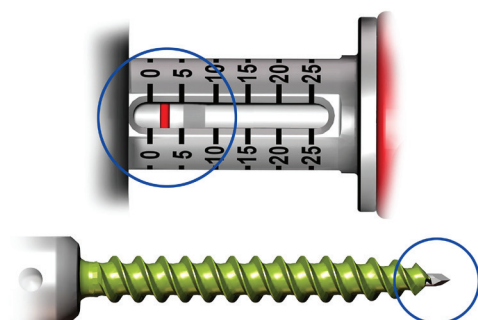


Fig 20



OPTIONAL: Dilator Insertion

- Assemble the Dilator to the Dilator Sleeve. The instruments will snap together. (Fig 21)
- Advance the assembled instrument until the distal tip contacts the pedicle. Confirm placement with fluoroscopy. (Fig 22)

The metal tip will be visible under fluoroscopy.

- Push down on the Dilator Sleeve while pulling back on the Dilator until it separates from the Dilator and contacts the bone. Remove the Dilator while holding the Dilator Sleeve in place. (Fig 23)

Fig 21



Fig 22



Fig 23



Step 3

Pedicle Targeting

- Insert the VIPER PRIME Inserter assembly through the incision and dock the stylet tip on the bony anatomy of the desired level. At initial insertion, the Stylet should extend past the tip of the screw to dock onto the pedicle. The Stylet can be extended further if needed to adequately dock to the posterior anatomy. Confirm the position using fluoroscopy. (Fig 24)
- Targeting forceps can be used to keep the surgeon's hand out of the fluoroscopy field. Attach the forceps just above the green knob on the Inserter.
- To extend the Stylet relative to the screw tip, turn the Red Stylet Control Handle clockwise. As the handle is turned, each "click" represents approximately 1 mm of stylet extension. Extend the Stylet no more than an additional 5 mm while applying gentle downward pressure to ensure the Stylet remains docked. (Fig 25 & 26)
- The screw will rise as you extend the Stylet. Using a mallet, gently tap the Modular Handle to advance the Stylet into the pedicle.

Precaution: It is not recommended to mallet on the Stylet when it is extended more than 5 mm beyond the tip of the screw outside of the bone.

Use the etched markings on the X-Tabs to ensure that you do not mallet the screw tip into the pedicle. Observe where the etched lines are relative to the skin prior to extending the Stylet once it is docked. This is your reference for when the screw tip is docked on the bone. Confirm the Stylet trajectory and position using A/P fluoroscopy.

Warning: If the Stylet trajectory is not monitored by fluoroscopy, there is a potential for pedicle or anterior wall breach, potentially resulting in neurological damage or damage to the great vessels.

Fig 24

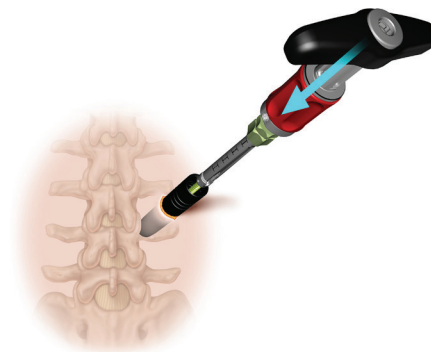


Fig 25

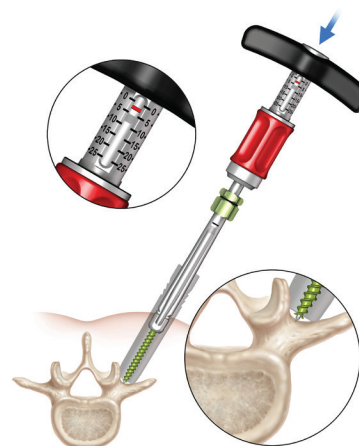
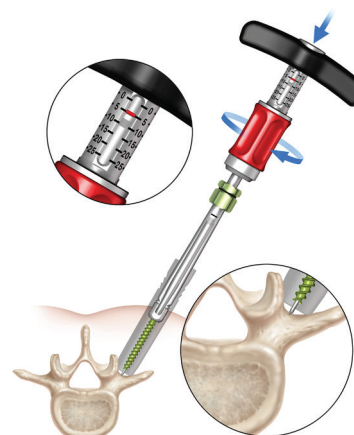


Fig 26



Pedicle Targeting continued

Observe screw position relative to the skin level using the markings on the X-Tabs as you extend the Stylet.

- Continue to advance the Stylet up to 5 mm at a time until it is fully advanced through the pedicle, up to a distance of 25 mm. Confirm the final position of the Stylet using A/P and lateral fluoroscopy. (Fig 27 & 28)

The distance between the tip of the Stylet and the tip of the screw is represented by the red line on the Stylet Depth Gauge which has 5 mm increments at the proximal end of the VIPER PRIME Inserter to help estimate the depth of the Stylet. This can be used to track the position of the Stylet while it is being advanced into the pedicle.

The 3 mm starting protrusion of the Stylet can vary ± 1.4 mm due to allowable manufacturing tolerances.

Fig 27

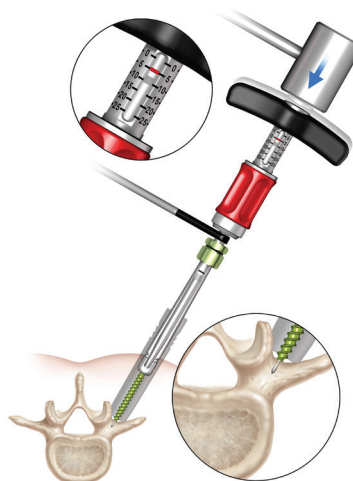
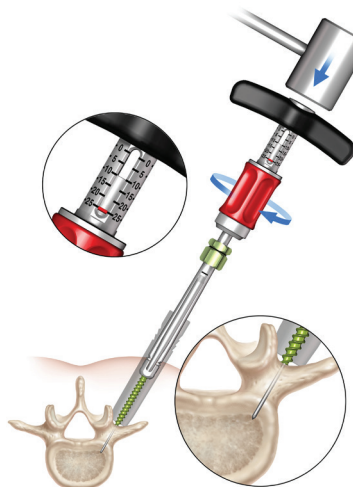


Fig 28



Step 4

Screw Insertion

- Once the Stylet has been extended, **HOLD THE RED STYLET CONTROL HANDLE** while rotating the proximal handle of the Inserter clockwise to advance the screw into the pedicle over the extended Stylet. Use the depth markings on the X-Tab to monitor the travel of the implant relative to the skin. (Fig 29)

Warning: It is critical to hold the Red Stylet Control Handle at all times while advancing the screw. Holding the Red Stylet Control Handle will retract the Stylet as the screw is advancing into the pedicle. As a result, the tip of the Stylet will not advance further into vertebral body as the screw is inserted. If the Red Stylet Control Handle is not held, the Stylet will remain extended and advance in front of the screw, potentially leading to a anterior wall breach, neurological damage or damage to the great vessels.

Reference the etched lines on the X-Tab to check that they move relative to the skin to ensure the screw is advancing.

- Once the Stylet is fully retracted, the Red Stylet Control Handle will no longer rotate independent of the Inserter assembly. The tip of the Stylet is now approximately 3 mm beyond the tip of the screw and can be confirmed by the red line position on the Stylet Depth Gauge at the proximal end of the Inserter. At this point, release the Red Stylet Control Handle and insert the screw the remaining distance using the proximal handle until the screw is fully seated. Be sure that the polyaxial head is still mobile when the screw is seated. (Fig 30)

Warning: It is recommended that fluoroscopy be used while inserting the screw to monitor the depth of the screw and ensure that the Stylet is not unintentionally advanced, which might lead to a breach of the anterior wall of the vertebral body, neurological damage or damage to the great vessels.

- Disengage the screw from the Inserter by fully unthreading the green knob from the proximal threads of the implant and remove the Inserter and Stylet using the Red Stylet Control Handle. Use caution when removing the Stylet from the screw. (Fig 31)

Fig 29

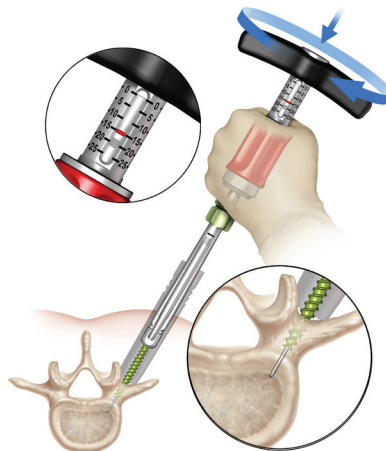


Fig 30

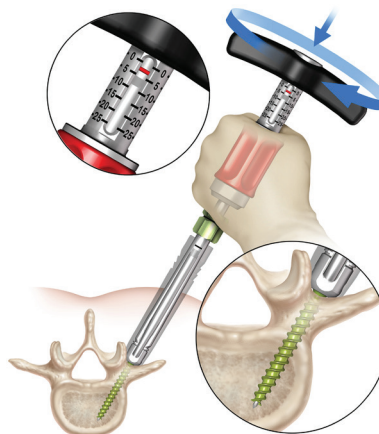


Fig 31



Step 4a

Insertion of Additional Screws

- Follow the previous steps for the remaining screws.

If the length of the subsequent screw is the same, the Stylet and Depth Adjustor do not need to be changed. If the length of the subsequent screw is different, remove the Depth Adjustor using the Set Screw Driver. Open the retaining sleeve and move the Stylet flange to the appropriate slot for the new screw length. (Fig 32)

After each screw, visually check the Stylet to ensure that it has not been damaged or bent during screw insertion. If it has, replace the Stylet with a new one before proceeding to the next screw.

Fig 32



Step 5 Optional

Cement Augmentation Procedure for Fenestrated Screws

When used in conjunction with CONFIDENCE High Viscosity Spinal Cement, the VIPER PRIME Fenestrated Screws are intended to restore the integrity of the spinal column even in the absence of fusion for a limited time period in patients with advanced stage tumors involving the thoracic and lumbar spine in whom life expectancy is of insufficient duration to permit achievement of fusion. The VIPER PRIME Fenestrated Screws augmented with CONFIDENCE High Viscosity Spinal Cement are for use at spinal levels where the structural integrity of the spine is not compromised.

Alignment of the Screw

- Insert the VIPER PRIME Fenestrated Alignment Device into the VIPER PRIME X-Tab and thread it into the screw head while holding the X-Tabs to provide counter torque. This will align the screw shank to the screw head. (Fig 33 & 34)
- Confirm that the alignment device is fully seated by checking that the alignment device handle and top of the X-Tab are in close proximity. The head will be locked to the shank when it is properly aligned.

Attachment of Additional Alignment Devices

Repeat until Alignment Devices are attached to all levels intended for cement augmentation. Do not mix the CONFIDENCE System cement until all alignment devices are attached at each level intended for augmentation.

Precaution: The alignment guide MUST be used for each screw intended for cement augmentation. Without the alignment guide, there is a potential risk of cannula breakage. Use of the alignment guide will prevent undue stress from being applied to the cannula.

Fig 33

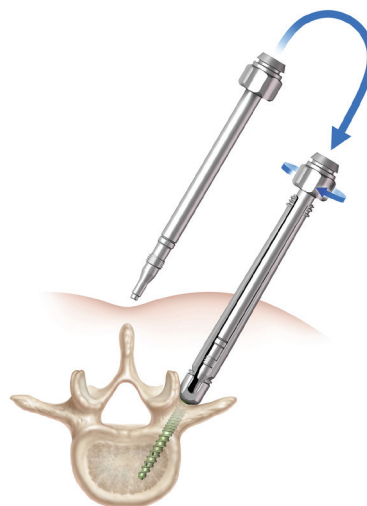
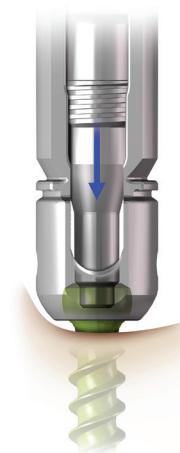


Fig 34



Cement Preparation and Delivery

- Once the screws are in place and the Alignment Devices are attached to the levels selected to be augmented, please refer to the VIPER Cortical Fix Fenestrated Screw System Guide for instructions on Cement Preparation and Delivery.

Precaution: Only the open cannulas are compatible with the VIPER PRIME X-Tabs.

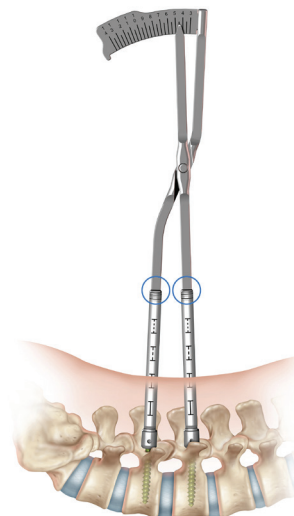
- Remove the alignment devices after cement has been delivered by holding the X-Tab and unthreading the device.

Step 6

Rod Measurement and Delivery

- Insert one arm of the Rod Gauge into each of the outermost X-Tabs until each leg is fully seated in the screw heads. Placement can be verified by ensuring that the circumferential lines on the shafts of the Rod Gauge align with the top of each X-Tab. (Fig 35)
- Straight rods can be measured using the markings on the Rod Gauge leg. The X-Tabs must be parallel to each other and the Rod Gauge should be laid on the body so that the legs are perpendicular to the tabs to ensure accurate measurement. Etch lines should be aligned with the outside edge of the X-Tabs for straight rod measurements.
- Length markings indicate rod length including rod overhang. No additional rod length allowance is required. Select the rod that corresponds with the indicated rod length. If the measurement is between two lengths, it is recommended to select the longer rod. The measurement accuracy of the Rod Gauge can vary ± 1.2 mm due to allowable manufacturing tolerances.

Fig 35



Rod Measurement and Delivery continued

Assemble the Rod Holder

The Rod Holder is made up of three components:

1. Push Rod (Fig 36)
2. Rod Holder Stem (Fig 37)
3. Threaded Shaft (Fig 38)

Fig 36



Fig 37

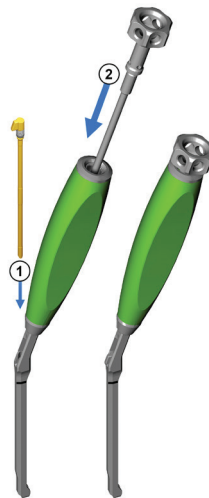


Fig 38



- Insert the Push Rod into the Rod Holder Stem. Ensure that the Push Rod is fully seated before inserting the Threaded Shaft. (Fig 39)
- Thread the shaft into the top of the Rod Holder Stem. (Fig 39)

Fig 39



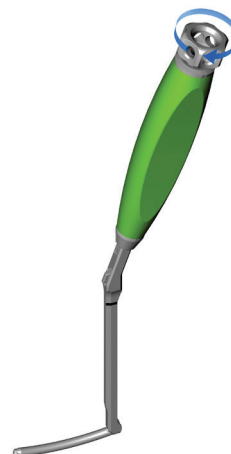
Attach Rod to the Rod Holder

- Insert the connection end of the rod into the pocket of the Rod Holder ensuring that the V-notch on the connection end of the rod is facing up towards the handle of the Rod Holder. (Fig 40)
- Tighten the knob on the proximal end of the Rod Holder to capture and lock the rod. Verify that the rod is securely attached to the Rod Holder. (Fig 41)

Fig 40



Fig 41



Rod Measurement and Delivery continued

Rod Insertion

- Align the slots of the X-Tabs so that they are in line with each other to allow for passage of the rod. Position the VIPER PRIME Rod Holder parallel to the skin's surface with the tip of the rod facing downward. (Fig 42)
- Insert the Rod Holder Assembly through the cranial screw extension tab, and advance the Rod Holder into the slot of the caudal Screw X-Tab(s). The entire rod should be contained within the X-Tabs.
- Use the Rod Holder to align the Screw X-Tabs until they are parallel with one another.
- Advance the distal end of the rod towards the screw, down the caudal X-Tab until it touches the top of the screw head or it is as deep as the tissue will allow. It is necessary for the distal end of the rod to be below the fascia before proceeding.

The rod is fully seated when the laser-etch line on the stem of the Rod Holder is aligned with the top of the X-Tabs. (Fig 43)

- To verify the rod has passed through the screw, twist the X-Tabs. If the tab is able to rotate, the rod is not contained within the tab and rod placement should be re-attempted. Fluoroscopy should be used to verify adequate rod overhang at each end of the construct.

Fig 42

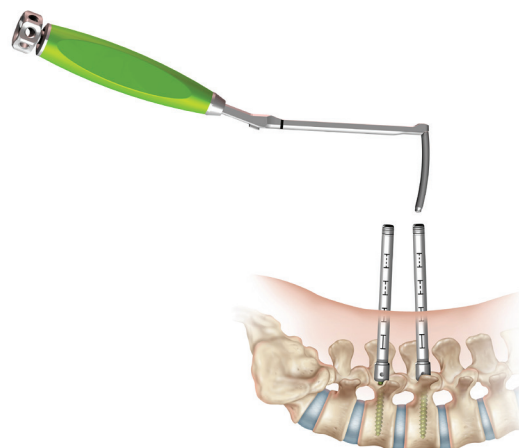
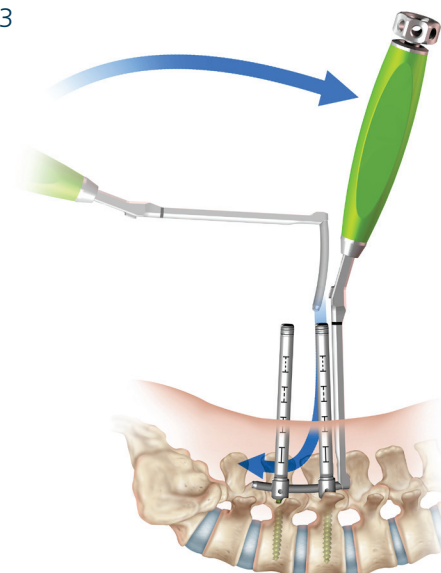


Fig 43



Step 7

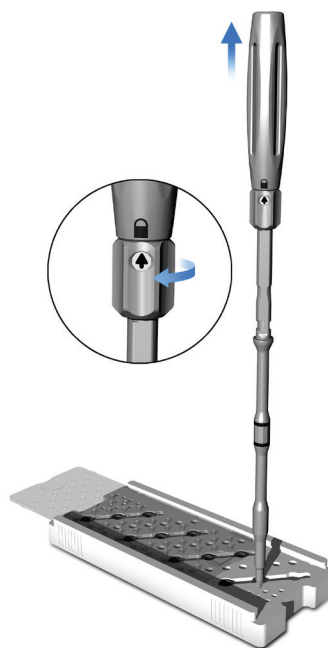
Set Screw Insertion

- Ensure that the Set Screw Driver Handle is in the unlocked position. Slide the Inserter lid on the Set Screw Caddy to uncover a single set screw. This will prevent other set screws from inadvertently becoming dislodged during set screw loading. (Fig 44)
- With the set screw in the caddy, fully seat the Set Screw Driver into the set screw. Raise and drop the slap handle to secure the set screw to the Set Screw Driver. (Fig 45)
- Return the handle to the proximal end of the Set Screw Driver and lock in place. (Fig 45)

Fig 44



Fig 45



- Use the Set Screw Driver to advance the set screw through the extension tabs and into the screw head. It is recommended to begin with the set screw closest to the Rod Holder. (Fig 46)

Precaution: If substantial reduction forces are expected during set screw insertion, the VIPER PRIME Counter-Torque should be used. This will allow the Set Screw Driver to fully reduce the rod into the head of the polyaxial screw and reduce the chance of tab splay and subsequent set screw cross threading.

- Once the proximal laser etch band on the shaft of the Set Screw Driver is in line with the top of the screw X-Tabs, then the set screw and rod are fully seated within the screw head. (Fig 47)

- Repeat for all screws

Slap handle can be used to remove the Set Screw Driver from the set screw

- After all set screws are placed, remove the Rod Holder.

If further correction is needed, remove the set screw Driver and proceed to next step. If no further correction is needed, proceed to final tightening.

Fig 46

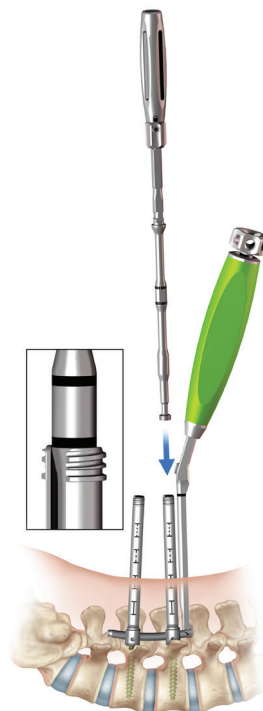
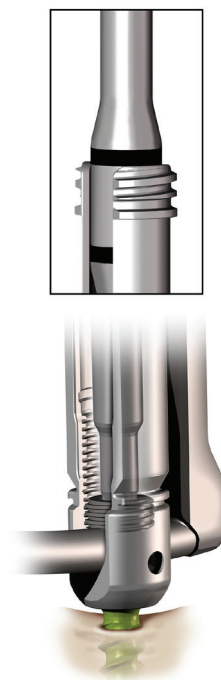


Fig 47



Step 8

Optional Compression Instructions

The Compressor consists of three components

1. Driver Leg (Fig 48)
2. Solid Compressor Leg (Fig 49)
3. X25 Compressor Driver (Fig 50)

Fig 48



Fig 49



Fig 50



Compression continued

- Final tighten one set screw and provisionally tighten the remaining set screws.

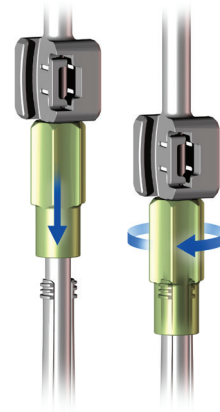
Please refer to Step 9 for final tightening instructions.

- Place the Driver Leg (1) through the X-Tab at the provisionally tightened set screw. (Fig 51)
- Secure the Driver Leg to the implant by threading the green knob onto the external threads at the proximal end of the X-Tab. (Fig 52)

Fig 51



Fig 52



Compression continued

- Place the Solid Compressor Leg (2) through the X-Tab with the final tightened set screw. (Fig 53)

Orient the foot of the Solid Compressor Leg so that it seats on the edge of the set screw and faces towards the disc space intended for compression. (Fig 54)

- Connect the compressor legs by sliding them together axially or by depressing the spring tab and sliding them together laterally. (Fig 55 & 56)

Fig 53



Fig 54



Fig 55

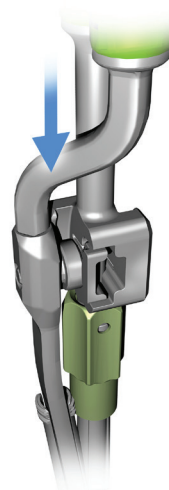


Fig 56



Compression continued

- Insert the X25 Compressor Driver (3) through the Driver Leg. (Fig 57)
- Slightly loosen the provisionally tightened set screw until the rod is free to slide in the screw head
- Squeeze the two handles together to compress while provisionally tightening the set screw. (Fig 58 & 59)

Precaution: The X25 Compressor Driver is only designed to be a provisional set screw tightener and not a final tightener. The Set Screw Driver and Final Tightening Torque Handle provided in the VIPER PRIME Instrument Set should be used for final tightening.

Fig 57



Fig 58

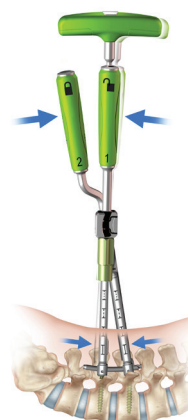


Fig 59



Compression continued

- Release the Compressor by unthreading the knob on the Driver Leg and remove both legs from the implants. (Fig 60 & 61)

For multi-level constructs, it is recommended to perform segmental compression.

Fig 60

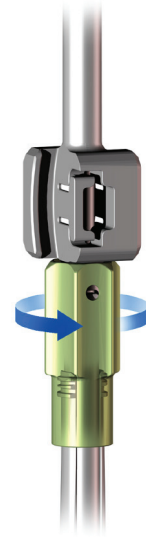


Fig 61



Step 9

Final Tightening

Using fluoroscopy, verify that the rod connection feature and bullet nose are both fully outside the screw heads.

- To perform final tightening, place the Counter-Torque over one of the X-Tabs. Ensure that the notches of the counter-torque straddle the rod. (Fig 62 & 63)
- Attach the Set Screw Driver to the Final Tightening Torque Handle with the handle in the lower locked position, pass through the X-Tab, and engage the set screw. (Fig 64)

Laser markings on the proximal end of the Counter-Torque Tube indicate the orientation of the rod slots.

- Rotate the Torque Wrench Handle clockwise, while applying counter-torque, until the torque handle clicks. The final torque applied will be 80 in-lbs. Repeat for all additional set screws. (Fig 65)

It is recommended to revisit all set screws to ensure a rigidly locked construct post operatively. Set screws should be flush with the top of the screw heads indicating they are fully seated. This can be confirmed using fluoroscopy.

Fig 62



Fig 63



Fig 64



Fig 65



Final Tightening continued

X-Tab removal

- Place the Tab Breaker over one tab ensuring the nose is in the rod slot. Advance the Tab Breaker until it reaches the set screw and can no longer be advanced. The laser marked line on the body of the Tab Breaker will line up with the top of the tab when fully seated. (Fig 66)
- Rock the Tab Breaker outward (away from the center of the screw) until the tab breaks away from the Screw Head. (Fig 67)

The tab will be retained inside the Tab Breaker. Remove the tab by depressing the button at the top of the Tab Breaker handle. Ensure that the tab is removed from the instrument prior to repeating this technique on the remaining tabs.

Fig 66

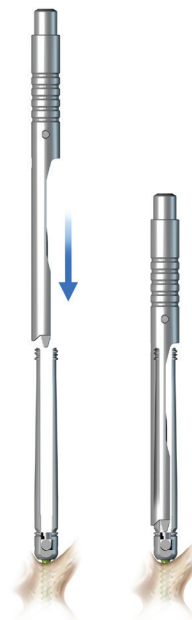
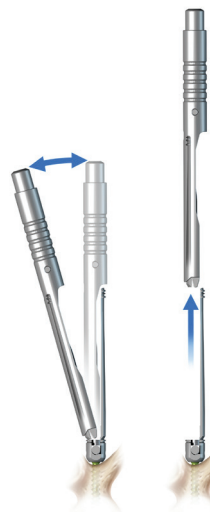


Fig 67



Removal Instructions

If a decision is made to remove the implants after solid fusion occurs, the following steps should be taken after the implant is exposed.

For set screw, rod and screw removal:

Clean debris/tissue from set screws

Connect the Torque Handle to the X25 Set Screw Inserter

Insert Counter Torque over targeted screw and engage Inserter with set screw

Turn the handle counter-clockwise to loosen set screw while applying counter torque

Once the set screws are removed, the rods can be removed

Engage Set Screw Inserter with screw shank and turn handle counter-clockwise to remove screw

Instruments

2867-50-082 Compressor Driver Leg



2867-50-083 Compressor Driver X25



2867-50-081 Compressor Solid Leg



2867-50-041 Stylet Depth Adjustor



2867-50-010 Dilator



2867-50-020 Dilator Sleeve



2867-50-033 Inserter Carrier



2867-50-034 Inserter Drive Tube



2867-50-032 Red Stilet Control Handle



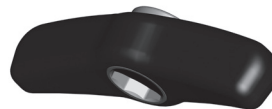
2867-50-031 Inserter Shaft



2867-50-036 Palm Handle



2867-50-035 T Handle



2867-50-110 Tab Breaker



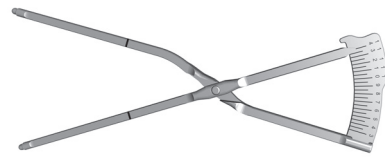
2867-50-150 Fenestrated Alignment Device



2867-50-090 Counter Torque



2867-50-050 Rod Gauge



2797-26-500 Fenestrated Open Cannula
(Pre-Packed Sterile/Single Use)



2867-50-140 Ratchet T Handle



2867-50-063 Rod Holder Push Rod



2867-50-062 Rod Holder Threaded Shaft



2867-50-061 Rod Holder Stem



2867-50-070 Set Screw Inserter



2867-50-200S Standard Stylet



2871-05-015 Targeting Forceps



2867-50-100 Torque Handle



2770-30-000 Rod Bender



Cases and Trays

286750510	VIPER PRIME Instrument Case
286750511	VIPER PRIME Instrument Tray 1
286750512	VIPER PRIME Instrument Tray 2
286750520	VIPER PRIME Implant Case
286750524	VIPER PRIME Top Implant Tray
286750525	VIPER PRIME Set Screw Caddy
286750521	VIPER PRIME X-TAB Impl Tray 1
286750526	VIPER PRIME X-TAB Impl Tray 2
286750523	VIPER PRIME CFXFEN X-TAB Tray
286750528	VIPER PRIME CFXFEN X-TAB Tray 2
286750600	VIPER PRIME Stylet Carry Case (Nav & Non Nav)
279792109	Case Lid
286750531	Prime Fen Aux Half Tray
299704840	Half Tray Lid

Implants

186745230	VIPER PRIME X-TAB, 4.5x30mm TI
186745235	VIPER PRIME X-TAB, 4.5x35mm TI
186745240	VIPER PRIME X-TAB, 4.5x40mm TI
186745245	VIPER PRIME X-TAB, 4.5x45mm TI
186745250	VIPER PRIME X-TAB, 4.5x50mm TI
186745255	VIPER PRIME X-TAB, 4.5x55mm TI
186745260	VIPER PRIME X-TAB, 4.5x60mm TI



186750230	VIPER PRIME X-TAB, 5x30mm TI
186750235	VIPER PRIME X-TAB, 5x35mm TI
186750240	VIPER PRIME X-TAB, 5x40mm TI
186750245	VIPER PRIME X-TAB, 5x45mm TI
186750250	VIPER PRIME X-TAB, 5x50mm TI
186750255	VIPER PRIME X-TAB, 5x55mm TI
186750260	VIPER PRIME X-TAB, 5x60mm TI



186760230	VIPER PRIME X-TAB, 6x30mm TI
186760235	VIPER PRIME X-TAB, 6x35mm TI
186760240	VIPER PRIME X-TAB, 6x40mm TI
186760245	VIPER PRIME X-TAB, 6x45mm TI
186760250	VIPER PRIME X-TAB, 6x50mm TI
186760255	VIPER PRIME X-TAB, 6x55mm TI
186760260	VIPER PRIME X-TAB, 6x60mm TI



186770230	VIPER PRIME X-TAB, 7x30mm TI
186770235	VIPER PRIME X-TAB, 7x35mm TI
186770240	VIPER PRIME X-TAB, 7x40mm TI
186770245	VIPER PRIME X-TAB, 7x45mm TI
186770250	VIPER PRIME X-TAB, 7x50mm TI
186770255	VIPER PRIME X-TAB, 7x55mm TI
186770260	VIPER PRIME X-TAB, 7x60mm TI



186775230	VIPER PRIME X-TAB, 7.5x30mm TI
186775235	VIPER PRIME X-TAB, 7.5x35mm TI
186775240	VIPER PRIME X-TAB, 7.5x40mm TI
186775245	VIPER PRIME X-TAB, 7.5x45mm TI
186775250	VIPER PRIME X-TAB, 7.5x50mm TI
186775255	VIPER PRIME X-TAB, 7.5x55mm TI
186775260	VIPER PRIME X-TAB, 7.5x60mm TI



Implants

186750435	VIPER PRIME CFXFEN XTAB 5x35mm
186750440	VIPER PRIME CFXFEN XTAB 5x40mm
186750445	VIPER PRIME CFXFEN XTAB 5x45mm
186750450	VIPER PRIME CFXFEN XTAB 5x50mm
186750455	VIPER PRIME CFXFEN XTAB 5x55mm
186750460	VIPER PRIME CFXFEN XTAB 5x60mm



186760435	VIPER PRIME CFXFEN XTAB 6x35mm
186760440	VIPER PRIME CFXFEN XTAB 6x40mm
186760445	VIPER PRIME CFXFEN XTAB 6x45mm
186760450	VIPER PRIME CFXFEN XTAB 6x50mm
186760455	VIPER PRIME CFXFEN XTAB 6x55mm
186760460	VIPER PRIME CFXFEN XTAB 6x60mm



186770435	VIPER PRIME CFXFEN XTAB 7x35mm
186770440	VIPER PRIME CFXFEN XTAB 7x40mm
186770445	VIPER PRIME CFXFEN XTAB 7x45mm
186770450	VIPER PRIME CFXFEN XTAB 7x50mm
186770455	VIPER PRIME CFXFEN XTAB 7x55mm
186770460	VIPER PRIME CFXFEN XTAB 7x60mm



Indications and Contraindications

Indications For Use

The EXPEDIUM and VIPER Spine Systems are intended to provide immobilization and stabilization of spinal segments in skeletally mature patients as an adjunct to fusion in the treatment of acute and chronic instabilities or deformities of the thoracic, lumbar and sacral spine.

The EXPEDIUM and VIPER Spine Systems are intended for noncervical pedicle fixation and nonpedicle fixation for the following indications: degenerative disc disease (defined as back pain of discogenic origin with degeneration of the disc confirmed by history and radiographic studies); spondylolisthesis; trauma (i.e., fracture or dislocation); spinal stenosis; curvatures (i.e., scoliosis, kyphosis, and/or lordosis); tumor, pseudoarthrosis; and failed previous fusion in skeletally mature patients.

When used in a posterior percutaneous approach with MIS instrumentation, the VIPER System is intended for noncervical pedicle fixation and nonpedicle fixation for the following indications: degenerative disc disease (defined as back pain of discogenic origin with degeneration of the disc confirmed by history and radiographic studies); spondylolisthesis; trauma (i.e., fracture or dislocation); spinal stenosis; curvatures (i.e., scoliosis, kyphosis, and/or lordosis); tumor, pseudoarthrosis; and failed previous fusion in skeletally mature patients. When used in conjunction with CONFIDENCE High Viscosity Spinal Cement, the VIPER and EXPEDIUM Fenestrated Screw Systems are intended to restore the integrity of the spinal column even in the absence of fusion for a limited time period in patients with advanced stage tumors involving the thoracic and lumbar spine in whom life expectancy is of insufficient duration to permit achievement of fusion. The VIPER and EXPEDIUM Fenestrated Screw Systems augmented with the CONFIDENCE High Viscosity Spinal Cement are for use at spinal levels where the structural integrity of the spine is not severely compromised.

Contraindications

- Disease conditions that have been shown to be safely and predictably managed without the use of internal fixation devices are relative contraindications to the use of these devices.
- Active systemic infection or infection localized to the site of the proposed implantation are contraindications to implantation.
- Severe osteoporosis is a relative contraindication because it may prevent adequate fixation of spinal anchors and thus preclude the use of this or any other spinal instrumentation system.
- Any entity or condition that totally precludes the possibility of fusion, i.e., cancer, kidney dialysis, or osteopenia is a relative contraindication. Other relative contraindications include obesity, certain degenerative diseases, and foreign body sensitivity. In addition, the patient's occupation or activity level or mental capacity may be relative contraindications to this surgery. Specifically, patients who because of their occupation or lifestyle, or because of conditions such as mental illness, alcoholism, or drug abuse, may place undue stresses on the implant during bony healing and may be at higher risk for implant failure.

The use of the fenestrated screws in conjunction with CONFIDENCE High Viscosity Spinal Cement is contraindicated in patients presenting with any of the following conditions:

- Disease conditions that have been shown to be safely and predictably managed without the use of internal fixation devices
- Acute compromise of the vertebral body or walls of the pedicles and disruption of the posterior cortex
- Anatomical damage of the vertebra that prevents safe screw implantation
- Active or incompletely treated infection
- Coagulation disorders, or severe cardiopulmonary disease.
- Haemorrhagic diathesis.
- Spinal stenosis > 20% caused by retracted fragments.
- Vertebral body collapse to less than 1/3 (33%) original height
- Coagulopathy or inability to reverse anti-coagulant therapy (both during and approximately 24 hours post-procedure).
- Allergic reaction to any of the components of the cement or metal used
- Relative contraindications include obesity, certain degenerative diseases, and foreign body sensitivity. In addition, the patient's occupation or activity level or mental capacity may be relative contraindications to this surgery. Specifically, patients who because of their occupation or lifestyle, or because of conditions such as mental illness, alcoholism, or drug abuse, may place undue stresses on the implant during bony healing and may be at higher risk for implant failure.

Following are specific warnings, precautions, and possible adverse effects that should be understood by the surgeon and explained to the patient. These warnings do not include all adverse effects that can occur with surgery in general, but are important considerations particular to metallic internal fixation devices. General surgical risks should be explained to the patient prior to surgery.

Warnings

1. CORRECT SELECTION OF THE IMPLANT IS EXTREMELY IMPORTANT. The potential for satisfactory fixation is increased by the selection of the proper size, shape, and design of the implant. While proper selection can help minimize risks, the size and shape of human bones present limitations on the size, shape and strength of implants. Metallic internal fixation devices cannot withstand activity levels equal to those placed on normal healthy bone. No implant can be expected to withstand indefinitely the unsupported stress of full weight bearing.
2. IMPLANTS CAN BREAK WHEN SUBJECTED TO THE INCREASED LOADING ASSOCIATED WITH DELAYED UNION OR NONUNION. Internal fixation appliances are load-sharing devices which are used to obtain alignment until normal healing occurs. If healing is delayed, or does not occur, the implant may eventually break due to metal fatigue. The degree or success of union, loads produced by weight bearing, and activity levels will, among other conditions, dictate the longevity of the implant. Notches, scratches or bending of the implant during the course of surgery may also contribute to early failure. Patients should be fully informed of the risks of implant failure.
3. MIXING METALS CAN CAUSE CORROSION. There are many forms of corrosion damage and several of these occur on metals surgically implanted in humans. General or uniform corrosion is present on all implanted metals and alloys. The rate of corrosive attack on metal implant devices is usually very low due to the presence of passive surface films. Dissimilar metals in contact, such as titanium and

stainless steel, accelerate the corrosion process of stainless steel and more rapid attack occurs. The presence of corrosion often accelerates fatigue fracture of implants. The amount of metal compounds released into the body system will also increase. Internal fixation devices, such as rods, hooks, etc., which come into contact with other metal objects, must be made from like or compatible metals.

4. **PATIENT SELECTION.** In selecting patients for internal fixation devices, the following factors can be of extreme importance to the eventual success of the procedure:

- A. The patient's weight. An overweight or obese patient can produce loads on the device that can lead to failure of the appliance and the operation.
- B. The patient's occupation or activity. If the patient is involved in an occupation or activity that includes heavy lifting, muscle strain, twisting, repetitive bending, stooping, running, substantial walking, or manual labor, he/she should not return to these activities until the bone is fully healed. Even with full healing, the patient may not be able to return to these activities successfully.
- C. A condition of senility, mental illness, alcoholism, or drug abuse. These conditions, among others, may cause the patient to ignore certain necessary limitations and precautions in the use of the appliance, leading to implant failure or other complications.
- D. Certain degenerative diseases. In some cases, the progression of degenerative disease may be so advanced at the time of implantation that it may substantially decrease the expected useful life of the appliance. For such cases, orthopaedic devices can only be considered a delaying technique or temporary remedy.
- E. Foreign body sensitivity. The surgeon is advised that no preoperative test can completely exclude the possibility of sensitivity or allergic reaction. Patients can develop sensitivity or allergy after implants have been in the body for a period of time.
- F. Smoking. Patients who smoke have been observed to experience higher rates of pseudarthrosis following surgical procedures where bone graft is used. Additionally, smoking has been shown to cause diffuse degeneration of intervertebral discs. Progressive degeneration of adjacent segments caused by smoking can lead to late clinical failure (recurring pain) even after successful fusion and initial clinical improvement.

The safety and effectiveness of pedicle screw spinal systems have been established only for spinal conditions with significant mechanical instability or deformity requiring fusion with instrumentation. These conditions are significant mechanical instability or deformity of the thoracic, lumbar, and sacral spine secondary to severe spondylolisthesis (grades 3 and 4) of the L5-S1 vertebra, degenerative spondylolisthesis with objective evidence of neurologic impairment, fracture, dislocation, scoliosis, kyphosis, spinal tumor, and failed previous fusion (pseudarthrosis). The safety and effectiveness of these devices for any other conditions are unknown.

Relevant to the use of the fenestrated screws in conjunction with CONFIDENCE High Viscosity Spinal Cement:

5. Refer to the VIPER and EXPEDIUM Fenestrated Screw Cannulas package insert for warnings associated with the use of the fenestrated screw cannulas.

6. Refer either to the package inserts of the CONFIDENCE High Viscosity Spinal Cement or CONFIDENCE Spinal Cement System kits for a list of warnings associated with the cement use. Follow the time temperature chart for mixing, delivery, and setting time of the cement used very carefully.

7. The fenestrated screws should NOT be placed bicortically. It is very important not to breach the pedicle wall or the anterior cortex of the vertebral body to avoid cement extrusion into the retroperitoneal space. This may result in serious complications, including cement extravasation, embolism or even death, especially if the cement is inadvertently delivered through the tip of the screw.

8. Pay special attention to the delivery system instructions from the corresponding package insert. Aggressive cement injection may result in cement leakage or extravasation.

9. Accurate pedicle preparation, screw sizing and placement must be practiced, as well as a careful cement delivery technique. There may be an increased risk of cement egress into pedicle if the screw length is too short for the vertebral body, or if excessive cement volume is pumped into the vertebral body.

10. When using cement to augment multiple screws or levels, attention must be paid not to exceed the working time of the cement prior to completion of cement delivery through the screw. When the cement working time is close to completion, a new cement package should be opened to mix and deliver cement through the next screw/level.

11. It is critical that NO torsion movement should be applied to the screw after injecting the cement in order to avoid breaking the cement bridges between screw and bone.

12. Do not continue injection beyond the working time of the cement. After cement introduction is complete, the fenestrated screw cement cannula must be removed immediately. The cement setting while the cannula is still connected to the screw may lead to difficulty in removal, and a new cannula may be required for additional levels.

13. Strict adherence to good surgical principles and techniques is essential. Deep wound infection is a serious post-operative complication and may require total removal of the embedded cement. Deep wound infection may be latent and may not manifest itself even for several years post-operatively.

14. Hypotensive reactions may occur with any procedure that involves cement use and some may progress to cardiac arrest. For this reason, patients should be monitored for any change in blood pressure during and immediately following the application of the cement.

15. Following cement introduction, positioning of the patient should be maintained securely throughout the setting phase as described in package inserts for either the CONFIDENCE High Viscosity Spinal Cement or CONFIDENCE Spinal Cement System kits.

16. The long-term safety and efficacy of fenestrated screws with cement augmentation have not yet been established.

17. The safety and efficacy of fenestrated screws in pregnant women or in children has not yet been established.

18. The mixing/delivery device is designed for single use with one package of spinal cement. If additional material is needed, use a second CONFIDENCE Spinal Cement System kit.

19. Do not re-sterilize any components packaged sterile. They are for single patient use only. These components are sterile only if the package is unopened and undamaged. DePuy Synthes will not be responsible for any product that is re-sterilized.
20. Extreme caution should be exercised when there is disruption to the posterior cortex of the vertebral body or the pedicle as this increases the risk of cement extravasation into the neural foramen or spinal canal.
21. Cement leakage can also occur when injecting CONFIDENCE High Viscosity Spinal Cement if cement enters a blood vessel or if unseen microfractures are prevalent.
22. If the CONFIDENCE High Viscosity Spinal Cement is seen outside of the vertebral body or in the circulatory system during the procedure, immediately stop injecting the cement. Turn the pump handle of the CONFIDENCE spinal cement delivery system counter-clockwise to stop the injection of the cement.
23. You may wish to consider the additional precaution of using Computerized Tomography (CT) guidance for high-risk cases.
24. Assure that all system components are firmly connected prior to cement introduction. Improperly secured connections could result in the unintended disconnection of components.
25. Always cancel the pressure within the system when cement introduction is no longer desired per the CONFIDENCE Spinal System kit package insert.
26. Do not attempt to force the injection of material if excessive resistance is felt. Always determine the cause of the resistance and take appropriate action.
27. Inadequate fixation or unanticipated post-operative events may affect device performance causing failure in any of several modes. These modes may include bone-metal, bone-cement and cement-metal interface, implant fracture or bone failure.
28. Cement leakage may cause tissue damage, nerve or circulatory problems, and other serious adverse events.

Precautions

1. **SURGICAL IMPLANTS MUST NEVER BE REUSED.** An explanted metal implant should never be reimplanted. Even though the device appears undamaged, it may have small defects and internal stress patterns which may lead to early breakage. Reuse can compromise device performance and patient safety. Reuse of single use devices can also cause cross-contamination leading to patient infection.
2. **CORRECT HANDLING OF THE IMPLANT IS EXTREMELY IMPORTANT.** Contouring of metal implants should only be done with proper equipment. The operating surgeon should avoid any notching, scratching or reverse bending of the devices when contouring. Alterations will produce defects in surface finish and internal stresses which may become the focal point for eventual breakage of the implant. Bending of screws will significantly decrease the fatigue life and may cause failure.
3. **CONSIDERATIONS FOR REMOVAL OF THE IMPLANT AFTER HEALING.** If the device is not removed following completion of its intended use, one or more of the following complications may occur: (1) Corrosion, with localized tissue reaction or pain; (2)

Migration of implant position possibly resulting in injury; (3) Risk of additional injury from postoperative trauma; (4) Bending, loosening, and/or breakage, which could make removal impractical or difficult; (5) Pain, discomfort, or abnormal sensations due to the presence of the device; (6) Possible increased risk of infection; (7) Bone loss due to stress shielding; and (8) potential unknown or unexpected long term effects such as carcinogenesis.

The surgeon should carefully weigh the risks versus benefits when deciding whether to remove the implant. Implant removal should be followed by adequate postoperative management to avoid refracture. If the patient is older and has a low activity level, the surgeon may choose not to remove the implant thus eliminating the risks involved with a second surgery.

4. **ADEQUATELY INSTRUCT THE PATIENT.** Postoperative care and the patient's ability and willingness to follow instructions are among the most important aspects of successful bone healing. The patient must be made aware of the limitations of the implant, and instructed to limit and restrict physical activities, especially lifting and twisting motions and any type of sports participation. The patient should understand that a metallic implant is not as strong as normal healthy bone and could loosen, bend and/or break if excessive demands are placed on it, especially in the absence of complete bone healing. Implants displaced or damaged by improper activities may migrate and damage the nerves or blood vessels. An active, debilitated, or demented patient who cannot properly use weight-supporting devices may be particularly at risk during postoperative rehabilitation.
5. **CORRECT PLACEMENT OF ANTERIOR SPINAL IMPLANT.** Due to the proximity of vascular and neurologic structures to the implantation site, there are risks of serious or fatal hemorrhage and risks of neurologic damage with the use of this product. Serious or fatal hemorrhage may occur if the great vessels are eroded or punctured during implantation or are subsequently damaged due to breakage of implants, migration of implants or if pulsatile erosion of the vessels occurs because of close apposition of the implants.

PHYSICIAN NOTE: Although the physician is the learned intermediary between the company and the patient, the important medical information given in this document should be conveyed to the patient. Relevant to the use of the fenestrated screws in conjunction with CONFIDENCE High Viscosity Spinal Cement:

6. The implantation of pedicle screw spinal systems should be performed only by experienced spinal surgeons with specific training in the use of this pedicle screw spinal system because this is a technically demanding procedure presenting a risk of serious injury to the patient. The surgeon must be thoroughly knowledgeable not only in the medical and surgical aspects of the implant, but must also be aware of the mechanical and metallurgical limitations of metallic surgical implants. The surgeon should also be familiar with the principles and technique of spinal cement delivery, including possible side effects and limitations, and with the physiology and pathology of the selected anatomy.
7. A thorough pre-operative check-up of the patient must be carried out before the operation.
8. Postoperative care is extremely important. The patient must be

- instructed in the limitations of the metallic implant and be warned regarding weight bearing and body stresses on the appliance prior to firm bone healing. The patient should be warned that noncompliance with postoperative instructions could lead to failure of the implant and possible need thereafter for additional surgery to remove the device.
9. During the application of the cement, radiological control is essential so that the operator can follow the progress of the filling and stop the procedure if the slightest leakage of cement is detected. Use appropriate imaging techniques such as fluoroscopy or CT imaging guidance to confirm correct screw placement, absence of damage to surrounding structures and appropriate location of injected cement.
 10. If surgeon chooses to complete a biopsy prior to screw placement, care should be taken not to place the tip of the biopsy needles beyond the desired location of the screw tip in order to reduce leakage or extravasation risk.
 11. The fenestrated screws must never be reused. An explanted implant should never be reimplanted. Even though a device appears undamaged after explanting, it may have small defects and internal stress patterns that may lead to early breakage.
 12. Reuse of single use implants and instruments may compromise device performance and patient safety and can also cause cross-contamination leading to patient infection.
 13. These procedures should only be performed in medical settings where emergency surgery is available.
 14. The CONFIDENCE Spinal Cement System kits are designed for use only with CONFIDENCE High Viscosity Spinal Cement. The device may not be compatible with alternate materials.

Possible Adverse Effects

1. Bending or fracture of implant.
2. Loosening of the implant.
3. Metal sensitivity or allergic reaction to a foreign body.
4. Infection, early or late.
5. Nonunion, delayed union.
6. Decrease in bone density due to stress shielding.
7. Pain, discomfort, or abnormal sensations due to the presence of the device.
8. Nerve damage due to surgical trauma or presence of the device. Neurological difficulties including bowel and/or bladder dysfunction, impotence, retrograde ejaculation, and paraesthesia.
9. Bursitis.
10. Paralysis.
11. Dural tears experienced during surgery could result in the need for further surgery for dural repair, a chronic CSF leak or fistula, and possible meningitis.
12. Death.
13. Vascular damage due to surgical trauma or presence of the device. Vascular damage could result in catastrophic or fatal bleeding. Malpositioned implants adjacent to large arteries or veins could erode these vessels and cause catastrophic bleeding in the late postoperative period.
14. Screw back out, possibly leading to implant loosening, and/or reoperation for device removal.
15. Damage to lymphatic vessels and/or lymphatic fluid exudation.
16. Spinal cord impingement or damage.
17. Fracture of bony structures.
18. Degenerative changes or instability in segments adjacent to fused vertebral levels.

Additional possible adverse effects specific to use of the fenestrated screws in conjunction with CONFIDENCE High Viscosity Spinal Cement: Please refer to the package inserts for the CONFIDENCE High Viscosity Spinal Cement and CONFIDENCE Spinal Cement System kits for adverse effects associated with the cement use.

1. Superficial or deep wound infection, early or late.
2. Vascular damage due to surgical trauma or presence of the device. Vascular damage could result in catastrophic or fatal bleeding. Malpositioned implants adjacent to large arteries or veins could erode these vessels and cause catastrophic bleeding in the late postoperative period. Also local vascular erosion and occlusion may result due to cement use.
3. Myocardial infarction and cardiac arrest which may result in death.
4. Pulmonary embolism which may result in death. Cement, fat or air emboli.
5. Anaphylaxis. Allergic pyrexia
6. Transitory fall in blood pressure.
7. Hypertension or hypotension.
8. Thrombophlebitis.
9. Hemorrhage and hematoma.
10. Cardiac arrhythmia.
11. Heterotopic bone formation.
12. Hypoxemia.
13. Bronchospasm.
14. Pain and/or loss of function. Transitory worsening of pain due to heat released during cement polymerization.
15. Hematuria or Dysuria.
16. Bladder fistula.
17. Local neuropathy.
18. Nerve entrapment and dysphagia due to extrusion of the bone cement beyond its intended application.
19. Intestinal obstruction because of adhesions and stricture of the ileum due to heat released during polymerization.
20. Sudden death.
21. Cerebrovascular accident.
22. Adverse tissue reaction.
23. Pneumonia.
24. Pulmonary infection.
25. Intercostal neuralgia, neuritis, nerve root pain, radiculopathy.
26. Pneumothorax.
27. Collapse of a vertebra adjacent to a treated level, due to osteoporotic disease.
28. Cement extravasation into soft tissue.
29. Cement leakage into intervertebral disc(s).
30. Skin burns from fluoroscopy exposure.
31. Hypersensitivity in susceptible persons, which may result in an anaphylactic response.

32. Adverse cardiovascular reaction.

MAGNETIC RESONANCE (MR) COMPATIBILITY

The VIPER and EXPEDIUM Spine Systems have not been evaluated for safety and compatibility in the MR environment. They have not been tested for heating, migration or image artifact in the MR environment. The safety of the VIPER and EXPEDIUM Spine Systems in the MR environment is unknown. Scanning a patient who has this device may result in patient injury.

For complete labeling, please refer to the instructions for use available electronically at www.e-ifu.com.

Limited Warranty and Disclaimer: DePuy Synthes products are sold with a limited warranty to the original purchaser against defects in workmanship and materials. Any other express or implied warranties, including warranties of merchantability or fitness, are hereby disclaimed.

Please also refer to the package insert(s) or other labeling associated with the devices identified in this surgical technique for additional information.

WARNING: In the USA, this product has labeling limitations. See package insert for complete information.

CAUTION: Federal Law restricts these devices to sale by or on the order of a physician.

Some devices listed in this surgical technique may not have been licensed in accordance with Canadian law and may not be for sale in Canada.

Please contact your sales consultant for items approved for sale in Canada.

Not all products may currently be available in all markets.



Note: For recognized legal manufacturer, refer to the product label.



DePuy Spine Inc.
325 Paramount Drive
Raynham, MA 02767
USA
Tel: +1 (800) 227-6633

Medos International SARL
Chemin-Blanc 38
2400 Le Locle
Switzerland

www.depuysynthes.com